

# Cluster Profile Report Faridabad - Mixed Engineering Cluster



Prepared for:  
**Small Industries Development Bank of India (SIDBI)**



  
**Disclaimer**

This document is an output of an exercise undertaken by DESL through a project funded by the Small Industries Development Bank of India (SIDBI) for the benefit of MSME units. While every effort has been made to avoid any mistakes or omissions, SIDBI would not be in any way liable to any person by reason of any mistake/omission in the publication.

**Suggested form of Citation**

DESL-2012

Cluster Profile Report – Faridabad Mixed Engineering Cluster

**Published By**

DESL

Development Environenergy Services Ltd

*Formerly Dalkia Energy Services Ltd*

**For More Information**

DESL

819, Antriksh Bhavan

22 Kasturba Gandhi Marg

New Delhi 110 001, India

Tel. +91 11 4079 1100 Fax. +91 11 40791101 Email [desl@deslenergy.com](mailto:desl@deslenergy.com)

[www.deslenergy.com](http://www.deslenergy.com)

Printed in India at New Delhi



*Conservation Redefined*

## TABLE OF CONTENTS

<b>Abbreviations</b>	<b>1</b>
<b>List of Tables</b>	<b>3</b>
<b>List of Figures</b>	<b>5</b>
<b>List of Annexes</b>	<b>6</b>
<b>Acknowledgement</b>	<b>7</b>
<b>Certificate of Originality</b>	<b>8</b>
<b>Executive Summary</b>	<b>9</b>
<b>1. About The Project</b>	<b>15</b>
<b>2. Methodology</b>	<b>16</b>
<b>3. Cluster Scenario</b>	<b>20</b>
<b>4. Major Cluster Actors</b>	<b>32</b>
<b>5. Technology Used, Production Process &amp; Technology status in Cluster</b>	<b>38</b>
<b>6. Estimated Energy Consumption pattern in Cluster &amp; Saving Potential</b>	<b>53</b>
<b>7. Major Challenges and Suggestions for improvement in the Cluster</b>	<b>62</b>
<b>8. SWOT Analysis</b>	<b>69</b>
<b>9. Conclusion</b>	<b>72</b>
<b>10. Annexes</b>	<b>73</b>

## ABBREVIATIONS

AGL	Adani Gas Ltd
CCC	Cluster Coordination Committee
CFL	Compact Fluorescent Lamp
CGD	City Gas Distribution
CMERI	Central Mechanical Engineering Research Institute
CNC	Computerised Numerical Control
DESL	Development Environenergy Services Ltd
DG	Diesel Generator
DHBVN	Dakshin Haryana Bijli Vitran Nigam
DIA	DLF Industries Association
DIC	District Industries Centre
DM	De Mineralised
DMIC	Delhi-Mumbai Industrial Corridor
EA	Executing Agency
EE	Energy Efficiency
FIA	Faridabad Industries Association
FO	Furnace Oil
FSIA	Faridabad Small Industries Association
GEF	Global Environment Facility
HPCB	Haryana Pollution Control Board
HSIDC	Haryana State Industrial Development Corporation
HUDA	Haryana Urban Development Authority
HWG	Hot Water Generator
IamSME	Integrated Association of Micro, Small & Medium Enterprises
IEX	Indian Energy Exchange
IIF	The Institute of Indian Foundrymen
kCal	Kilo Calories
kg	Kilogram
KMP	Kundli Manesar Palwal
kV	Kilo Volt
kVA	Kilo Volt Ampere
kVAh	Kilo Volt Ampere Hour
kW	Kilo Watt
Ltd	Limited
MAF	Manufacturer's Association, Faridabad
Manf	Manufacturer
MCF	Municipal Corporation of Faridabad
MJ	Mega Joule
MRIU	Manav Rachna International University

MSME	Micro, Small and Medium Enterprises
NA	Not Available
NH	National Highway
NHPC	National Hydro Power Corporation
NIT	New Industrial Town
OEM	Original Equipment Manufacturer
PFD	Process Flow Diagram
PNG	Piped Natural Gas
PSU	Public Sector Undertaking
Pvt	Private
PXIL	Power Exchange of India Limited
SBH	State Bank of Hyderabad
SBI	State Bank of India
SCM	Standard Cubic Meter
Sec	Sector
SIDBI	Small Industries Development Bank of India
SME	Small & Medium Enterprise
SSI	Small Scale Industry
VFD	Variable Frequency Drive
WTA	Walk Through Audit

## LIST OF TABLES

Table 1 Energy Consumption Pattern in the different Industry Segments .....	11
Table 2 Challenges Faced and Possible Solutions .....	12
Table 3 SWOT Analysis.....	13
Table 4 List of key stakeholders visited by DESL.....	17
Table 5 Industrial segments in Faridabad with Population Size and Sample Size .....	18
Table 6 Raw Material Used & Products Manufactured .....	25
Table 7 Percentage of units who had invested in the last 5 years .....	26
Table 8 Break-up of units invested in the last 5 years .....	26
Table 9 Sectoral analysis of pattern of investments in the past 5 years .....	26
Table 10 Current Market Scenario of industrial sectors .....	27
Table 11 Cluster Level Turnover and Employment.....	29
Table 12: CEPI values for Faridabad.....	31
Table 13 Industrial Associations in Faridabad .....	32
Table 14 Government Bodies associated with MSMEs in Faridabad .....	33
Table 15 Academic and R&D Institutions in Faridabad Cluster .....	34
Table 16 Service/Technology Providers in Faridabad Cluster (Partial List) .....	34
Table 17 Lead Bank in Faridabad Cluster.....	36
Table 18 Other National and Commercial Banks in Faridabad Cluster.....	36
Table 19 Financial Institutions in Faridabad Cluster .....	37
Table 20 Re-organisation of sectors .....	38
Table 21 Major Equipments used in the Auto Parts .....	39
Table 22 Products and Production Capacities of Units Surveyed – Auto Sector .....	40
Table 23 Main Process Equipment in Chemical Industries .....	40
Table 24 Products and Production Capacities of Units Surveyed –Chemical/Paint Sector .....	41
Table 25 Major Equipments used in the Auto .....	42

Table 26 Main Process Equipment in Electroplating Units .....	43
Table 27 Main Equipment in Fabrication Units .....	45
Table 28 Main Equipment for Railway Products/ Industrial Fasteners .....	46
Table 29 Main Plant and Equipment in Forging Plant .....	48
Table 30 Main Plant and Equipment in a Foundry .....	49
Table 31 Production Capacity in Foundries Surveyed .....	50
Table 32 Main Plant and Equipment - Moulding & Wire Drawing .....	50
Table 33 Main Plant and Equipment – Textile & Garment Manufacturing .....	51
Table 34 Energy Types, Specification, price & source used in Faridabad Cluster .....	53
Table 35 Industry Sector Electricity Connections: DHBVN, Faridabad .....	60
Table 36 Energy Saving Potential in Various Sectors .....	60
Table 37 Technology related challenges faced by MSME units in Faridabad .....	62
Table 38 Dependence on Diesel Generation set for electricity .....	64
Table 39 Minimum wages in Haryana, Punjab & Rajasthan .....	67
Table 40 Suggestions for improvement in the Cluster .....	67
Table 41 Sectoral SWOT Analysis.....	69

## LIST OF FIGURES

Figure 1 Dimension of information to be collected .....	16
Figure 2 Example of dimensions of information to be collected .....	16
Figure 3 Methodology for gathering data .....	17
Figure 4 Map of India, Haryana State and Faridabad .....	20
Figure 5 Growth of registered industrial units in Faridabad.....	21
Figure 6 Scale of units in Faridabad .....	22
Figure 8 MSME Units - Ownership Pattern .....	23
Figure 7 Year of establishment of units by scale .....	23
Figure 9 Ownership pattern scale-wise .....	24
Figure 10 Are MSMEs aware of EE equipments/machines?.....	24
Figure 11 Male-Female employees in units.....	30
Figure 12 PFD of an Auto Components / Auto Ancillary unit .....	39
Figure 13 PFD of a soap manufacturing unit .....	41
Figure 14: PFD of die casting unit .....	42
Figure 15 PFD of a typical electroplating unit.....	44
Figure 16 PFD of a fabrication unit .....	45
Figure 17 PFD of a typical Machine Manufacturing unit .....	47
Figure 18 PFD of a forging unit .....	48
Figure 19 PFD of a foundry .....	49
Figure 20 PFD of a typical Plastic Moulding Unit.....	51
Figure 21 PFD of a leather goods manufacturing unit .....	52
Figure 22 Sectoral Energy Mix: Cost Based.....	59
Figure 23 Monthly Variation in the pre-tax price of PNG in Rs/SCM.....	65
Figure 24 Employee Intensity per industry segment .....	66



## LIST OF ANNEXES

Annex 1 Questionnaire for Primary Survey .....	73
Annex 2 Database of Units Covered under Survey .....	84

## ACKNOWLEDGEMENT

DESL places on record its sincere thanks to the World Bank for its role in guiding and steering this prestigious assignment for “providing project development support for enhancement of energy efficiency” at Faridabad Mixed Engineering cluster.

DESL is grateful to the Small Industries Development Bank of India (SIDBI) for its progressive management and also for vesting its confidence in DESL to carry out this prominent assignment for the Faridabad Mixed engineering cluster and providing full fledged coordination and support throughout the study.

The DESL team is thankful to the office bearers of Faridabad Small Industries Association (FSIA) & the Integrated Association of Micro Small and Medium Enterprises of India (IamSME of India) for showing keen interest in the study and providing their whole hearted support and cooperation for the preparation of this cluster profile report. We would like to extend our special thanks to

- Mr. Rajive Chawla, President, FSIA
- Mr. Rahat Bhatia, Team Leader of Energy Efficiency Project, IamSME
- Mr. Saket Garg Co-Team Leader of Energy Efficiency Project, IamSME

DESL would also like to place on record the valuable inputs received through interactions and deliberations with the state government officials associated with this cluster. Interactions with cluster coordinating agencies, cluster coordination committee members, entrepreneurs, technology providers who were directly or indirectly involved throughout the study are also gratefully acknowledged.

**DESL**

## CERTIFICATE OF ORIGINALITY

This is to certify that this report is the original work of DESL. The study was jointly carried out by DESL team and Nielsen India (P) Ltd. The teams held detailed discussions and collected data from numerous industry stakeholders which covered Micro, Small, and Medium Enterprise (MSME) entrepreneurs, senior plant engineers, industry associations, key local bodies, local service providers, suppliers, fabricators, manufactures, experts, testing labs, academic institutes/ITIs, banks/FIs, and local energy distribution companies. In addition to this, the team reviewed secondary literature available on the cluster. The cluster profile is an end product of both first-hand interactions/data and secondary literature on the cluster. Appropriate references have been indicated in places where secondary sources of data and information have been utilized.

## EXECUTIVE SUMMARY

Small Industries Development Bank of India (SIDBI) and Bureau of Energy Efficiency (BEE) are jointly implementing a Global Environment Facility (GEF)/World Bank funded project, which aims at promoting energy efficiency in Micro, Small and Medium Enterprises (MSMEs) in five clusters viz Ankleshwar Gujarat), Faridabad (Haryana), Kolhapur (Maharashtra), Pune (Maharashtra) and Tirunelveli (Tamil Nadu).

Development Environenergy Services Limited (DESL, formerly Dalkia Energy Services Ltd.) has been assigned to provide project development support for two of the aforementioned clusters- Faridabad and Tirunelveli. The main objective of the project is to create demand for energy efficiency investments in the clusters. DESL's scope of work in the assignment includes cluster profiling, carrying out walk through assessments in at least 400 units, detailed energy audits in at least 250 units and implementation support in at least 200 units for energy cost reduction project implementation.

This report has been prepared based on literature review of past work carried out in the Faridabad cluster, primary survey carried out with 400 units in Faridabad and interaction with key stakeholders.

## CLUSTER SCENARIO

Faridabad, one among the 21 districts in the state of Haryana, came into existence on 15<sup>th</sup> August 1979 and is situated in the South East corner. Faridabad, just 25 km away from Delhi, was a part of the Pakistani Refugee Resettlement Project. In Faridabad, it was the refugees who initiated the industrial development projects of the city in the 1950s. The evolution of the MSME units in Faridabad is said to have spurred due the setting up of big industries in the field of auto parts, tractors, shoes etc. Due to the presence of auto majors like Escorts and Eicher, the cluster got developed.

There are an estimated 364 Medium size units (3%), 7039 Small Size units (59%) and 4612 micro size units (38%) in Faridabad cluster with the ownership pattern being 7,646 units (64%) as Sole Proprietorship Companies, 2,913 units (24%) as Private Ltd Companies, 1,092 units (9%) as Partnership Companies and 364 units (3%) as Public Ltd Companies<sup>1</sup>. The nature of raw materials used depends on the industry and the type of product being manufactured. There are majorly 15 industrial segments in the cluster with a high range of products from soaps to Tractors. The top 3 industry segments catering to 60% of the overall number of units present in Faridabad are the Automobile Parts (35%), Sheet Metal Components (14%) & Fabrication (11%). The remaining 12 industrial segments contribute to 40% of the total units in Faridabad. Thus the major raw material consumed in Faridabad are metal sheets of different gauges and the type of products manufactured are Spring Leaves, Clutch Plates, Steel Tubes, Bumpers, all kinds of metal auto parts, Cranes, Fans, Exhaust Systems, Heat Exchanger etc. Out of 400 units surveyed during the study, 334 units (83.5%) had invested in plant/machinery in last 5 years. Out of the 334 units, 234 units have funded the

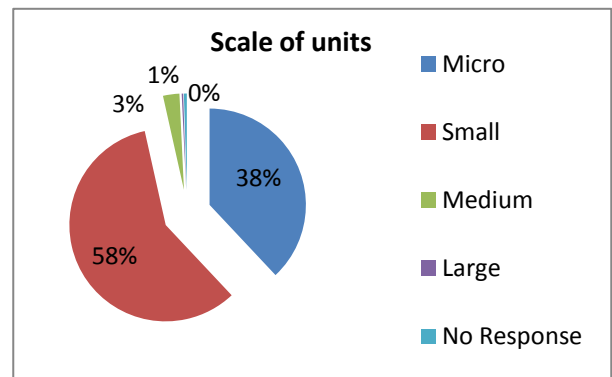

<sup>1</sup> Results of primary survey conducted under the project

investment either from a bank or own resource. Out of 234 units, 167 units (71.4%) have confirmed investment done from own sources and 66 units (28.2%) from banks and 1 unit (0.4%) from MFI. From the remaining 100 units who have funded investments from multiple sources, 12 units (12%) have clearly mentioned sourcing from SIDBI.

10 of the 15 industrial segments in Faridabad cater to the automobile market. The list of OEMs served by the industrial units in Faridabad are Escorts, Mahindra, Eicher, Yamaha, Maruti, Honda Siel Cars, New Holland etc who provide a steady opportunity to the units in Faridabad. Though there is a slowdown in the automobile manufacturing segment in general, this is perceived to be related to short term reasons. The report of the Working Group on Automotive Sector for the 12<sup>th</sup> Five Year Plan (2012-17) forecasts India to be the third largest vehicle market in the world by 2020. Moreover, the market for tractors has been quite steady supporting good business to the units in Faridabad. The other top markets catered by the units are the Construction and Domestic Products market, which are positive. The cluster level turnover has been estimated to be around 106, 66, 801 Lakh Rs with an employment potential of 8, 58, 499 people (permanent & contract included). An estimated average 15% of the employees are female, with the Railway Products & Electroplating Industry having the maximum percentage of 35% & 29% respectively. Faridabad Industrial cluster was ranked as the 18<sup>th</sup> most polluting cluster among the 88 clusters in India according to a study conducted by the Central pollution Control Board (CPCB) in 2009. While none of the 400 units surveyed under the primary survey mentioned any problem with environmental aspects, industrial units in the non-conformity area are facing problem in obtaining the Consent to Operate (CTO) from the PCB.

## MAJOR CLUSTER ACTORS

The key stakeholders in the cluster include the following

- **Industry Association:** There are majorly around 10 local Industry Associations in Faridabad, out of which 7 are geography specific and 3 are industry specific. Nearly 88% of units are members of one or the other industry association in Faridabad with maximum membership in the local associations (81%)<sup>1</sup>.
- **Government Organizations:** The main government organizations with whom the industries in Faridabad engage include the District Industries Centre (for setting up industry, getting requisite clearances and hand holding to resolve issues); Dakshin Haryana Bijli Vitran Nigam (DHBVN), the local power distribution utility (for new power supply connections, change requests in contract demand, billing related matters for regular and open access consumers, schedule of power cuts etc), the Haryana State Pollution Control Board (for pollution clearance), the local industrial estate developers like Haryana Urban Development Authority (HUDA) and Haryana State Industrial Development Corporation (HSIIDC) (for approval on change in plot usages, Financial Services etc), Municipal Corporation of Faridabad (for common local operational issues related to water supply, drainage etc) and the Labour Department, Haryana (for regular check of compliance on laws related to labour & fire safety by the Haryana Safety Council).
- **Academic and R&D Institutions:** There are a few institutions like The Institute of Indian Foundrymen (IIF), which focuses on the capacity building of entrepreneurs in the foundry sector in Faridabad and academic institutions like Manav Rachna International University (MRIU), which provides training to engineering students in the premises of the industrial unit for process re-engineering along with FSIA.
- **Vendors:** There are several vendors in and around Faridabad, who locally serve the industries. Also vendors of international repute who serve the industries. Some of the items like furnaces, Cupola are fabricated in the premises of the industrial unit by vendors.
- **Banks:** The lead bank in Faridabad is State Bank of India with more no of branches and business. Further there are a host of other banks and Financial Institutions like SIDBI, HSIIDC, HFC etc who serve the financial needs of the industries.

## ESTIMATED ENERGY CONSUMPTION PATTERN IN CLUSTER & SAVING POTENTIAL

Among the 15 industrial segments majorly present in Faridabad, the major 7 types of energy used are Electricity, Diesel, Coal/Coke, piped Natural Gas, Liquefied Petroleum Gas, Furnace Oil and Pet Coke. Due to the erratic power supply from DHBVN, each and every unit has to depend on DG sets for their electricity needs during power cuts. However, there are quite a few units using Diesel for other applications too. The following table shows the energy consumption pattern and the percentage of such occurrence.

Table 1 Energy Consumption Pattern in the different Industry Segments

Industry Segment	Type 1	Type 2	Type 3
<b>Auto parts</b>	Electricity (39%) & Diesel (61%); (100%)	-	-
<b>Casting</b>	Electricity (32%) & Diesel (68%); (62%)	Electricity (10%), Diesel (16%) & Coal (74%); 35%	Electricity (21%), Diesel (28%) & PNG (51%); 30%
<b>Chemicals/Paint/Powder</b>	Electricity (45%) & Diesel (55%); (82%)	Electricity (10%), Diesel (34%) & LPG (54%); 18%	-
<b>Die Casting</b>	Electricity (40%) & Diesel (60%); (78%)	Electricity (24%), Diesel (34%) & FO (42%); 16%	Electricity (28%), Diesel (29%) & PNG (43%); 6%
<b>Electroplating</b>	Electricity (43%) & Diesel (66%); (100%)	-	-
<b>Fabrication</b>	Electricity (46%) & Diesel (54%); (100%)	-	-
<b>Forgings</b>	Electricity (24%), Diesel (29%) & FO (47%); (47%)	Electricity (41%) & Diesel (54%); (40%)	Electricity (22%), Diesel (49%) & LPG (25%); (13%)
<b>Heat Treatment</b>	Electricity (36%) & Diesel (61%); (45%)	Electricity (25%), Diesel (25%) & FO (50%); (35%)	Electricity (16%), Diesel (29%) & LPG (55%); (15%)
<b>Industrial Fasteners</b>	Electricity (12%) & Diesel (88%); (100%)	-	-
<b>Foundry</b>	Electricity (6%), Diesel (17%) & Coke (78%); (69%)	Electricity (14%), Diesel (70%) & LPG (15%); (10%)	Electricity (6%) & Diesel (17%); (21%)
<b>Plastic/Plastic Products</b>	Electricity (50%) & Diesel (50%); (100%)	-	-
<b>Railway Equipment</b>	Electricity (50%) & Diesel (50%); (100%)	-	-
<b>Rubber Products</b>	Electricity (50%) & Diesel (50%); (96%)	Electricity (16%), Diesel (14%) & Coal (70%); (6%)	-
<b>Sheet Metal Components</b>	Electricity (40%) & Diesel (60%); (100%)	-	-
<b>Textile &amp; Garments</b>	Electricity (50%) & Diesel (50%); (71%)	Electricity (23%), Diesel (19%) & Coal (60%); (26%)	Electricity (25%), Diesel (35%) & Petcoke (39%); (3%)

## MAJOR CHALLENGES AND SUGGESTIONS FOR IMPROVEMENT IN THE CLUSTER

The major challenges and solutions faced by the cluster are listed in the table below:

Table 2 Challenges Faced and Possible Solutions

Challenge	Solution
<b>Technology Related</b>	
<ul style="list-style-type: none"> <li>• Replica of OEM technology available locally, but with a compromise on energy efficiency in the Die Casting and Forging industry</li> </ul>	<ul style="list-style-type: none"> <li>• Capacity Building of local vendors on improving the performance of their design</li> </ul>
<ul style="list-style-type: none"> <li>• High end technology proves costly for competitive rates in the auto parts, Sheet Metal and Fabrication industries</li> </ul>	<ul style="list-style-type: none"> <li>• Financial support of OEM technology or capacity building of local vendor for low cost option or collective bargaining through the local associations for better deals</li> </ul>
<ul style="list-style-type: none"> <li>• Retrofit ideas need technical support for design and some handholding from local vendors</li> </ul>	<ul style="list-style-type: none"> <li>• Detail design of new ideas identified under the project along with local vendor, as a demonstration for the segment for replication</li> </ul>
<b>Energy Related</b>	
<ul style="list-style-type: none"> <li>• 11 of the 15 industrial segments (except Railway Products, Electroplating/Metal Finishing, Chemical/Paint and Fabrication) were found to be spending more than 100% of cost of electricity to DHBVN on diesel in DG sets</li> </ul>	<ul style="list-style-type: none"> <li>• Verification of loading of DG set for optimal utilisation of DG &amp; periodic verification of DG performance. Avail open access under single or group customer basis, if possible &amp; seek information in advance about power supply schedule from DHBVN</li> </ul>
<ul style="list-style-type: none"> <li>• Frequent revisions of price of PNG to more than 33% in 12 months (FY 11-12) and 38% in the last 19 months</li> </ul>	<ul style="list-style-type: none"> <li>• Focus on improving productivity, energy efficiency, continuous evaluation of alternate fuel sources &amp; other cost reduction measures</li> </ul>
<b>Marketing Related</b>	
<ul style="list-style-type: none"> <li>• Auto cluster are dependent on large players. For e.g. the recent problem at the Maruti Manesar unit has resulted in loss of production in MSME units in the cluster</li> </ul>	<ul style="list-style-type: none"> <li>• Diversification of tie-ups with OEMs to overcome prevailing problems with any one particular OEM</li> </ul>
<ul style="list-style-type: none"> <li>• Some of the electroplating units conducting job work were found to be struggling with low capacity utilisation and short time allotted for the batch processing at times</li> </ul>	<ul style="list-style-type: none"> <li>• Focus on improving productivity</li> </ul>
<b>Raw Material Related</b>	
<ul style="list-style-type: none"> <li>• The plastic products/rubber products and textile units have concerns about the fluctuation of price of raw material. In the case of plastic moulding units, some of them import the raw material to avoid</li> </ul>	<ul style="list-style-type: none"> <li>• Look for opportunity to Import raw material when at low prices</li> </ul>
<b>Manpower Related</b>	
<ul style="list-style-type: none"> <li>• The top 5 industrial segments with high dependence on manpower are Electroplating/Metal Finishing, Foundry, Textile, Sheet Metal, Railway Products and Industrial Fasteners</li> </ul>	<ul style="list-style-type: none"> <li>• Focus on manpower optimisation through automation, continuous evaluation of permanent manpower Vs contract manpower etc</li> </ul>
<ul style="list-style-type: none"> <li>• Most industries are heavily dependent on one to a few key persons for managerial aspects</li> </ul>	<ul style="list-style-type: none"> <li>• Develop alternate manpower to handle managerial aspects through proper training</li> </ul>
<ul style="list-style-type: none"> <li>• Technical awareness level is relatively low as compared</li> </ul>	<ul style="list-style-type: none"> <li>• Focus on training of existing staff or hiring semi-</li> </ul>

to larger industries sometimes causing a hurdle to shift to latest technologies	<p>skilled manpower when required for more latest technologies</p> <ul style="list-style-type: none"> <li>• Technology development for low cost energy management and monitoring systems, suitable for the skill set easily available</li> </ul>
<b>Social Related</b>	
<ul style="list-style-type: none"> <li>• The expectation of social cost of labour (including the expense of hospitalisation) has increased causing either cost implication to the unit owner or higher attrition</li> </ul>	<ul style="list-style-type: none"> <li>• Clearly articulate the extent of cost to be borne by the industry's management &amp; continuously evaluate the same</li> </ul>
<ul style="list-style-type: none"> <li>• The internal road and infrastructure in the industrial area has been poor causing a dusty environment</li> </ul>	<ul style="list-style-type: none"> <li>• Follow-up through the local associations to discuss with the state government on the improvement of internal roads and infrastructure</li> </ul>
<ul style="list-style-type: none"> <li>• Interventions in the recent past on energy efficiency has left an impression of minimal options for low cost energy cost reduction measures possible</li> </ul>	<ul style="list-style-type: none"> <li>• This project has been designed to build confidence of the entrepreneur that the energy efficiency technical consultants would strive to identify low cost measures &amp; also help them implement the same. However, the time horizon of implementation is governed by the situation of resources with the unit and the proficiencies of the local vendors with whom the units generally get modifications done</li> </ul>
<b>Environmental Related</b>	
<ul style="list-style-type: none"> <li>• Some of the industrial areas like Saroorpur Industrial Area, Krishna Colony etc fall under the non-conformity areas, where there is a relaxation on the compliance on environmental aspects. Several foundry and environmentally polluting units have developed in these areas</li> </ul>	<ul style="list-style-type: none"> <li>• Follow-up through the local associations to discuss with the state government on the converting the non-conformity areas to conformity areas or allot plots in the upcoming IMT Faridabad</li> </ul>

## SWOT ANALYSIS

The following table shows the analysis of internal strengths & weakness and external opportunities & threats i.e. SWOT analysis

Table 3 SWOT Analysis

Elements of SWOT (Strength, Weakness, Opportunities & Threat)
<b>Strength</b>
Auto components industry has an established tie-ups with OEMs for orders
The penetration of plastic products in the market coupled with the low cost of making die has helped in providing flexibility for higher capacity utilisation
High variations in the cost of raw material for plastic, rubber and polyester textile units
Several industrial units were found to have been established by the members of the same family, mostly in similar sectors, hence getting good overall support (Forging, Industrial Fasteners, Foundry, plastic 7 Sheet Metal)
<b>Weakness</b>
Labour intensive units face the problems of rising cost of labour and high attrition



Elements of SWOT (Strength, Weakness, Opportunities & Threat)
Die Casting units have high cost of die making thus prohibiting them from moving to other products quickly
Managerial capability is mostly limited to 1-2 persons who shoulder most of business responsibilities
Human Resources development is not a focus
Value addition of product is low in rubber units, thus not demanding high cost
<b>Opportunity</b>
Well established cluster known for auto components
Several associations, to address to the industry's needs
Local Industry segment specific associations available for specific issues
Several OEM's are involved in mentoring and development of MSME units who are their vendors (Auto Parts, Sheet Metal & Die Casting)
Some sectoral consultants were found to be visiting the units (atleast medium scale units or group companies) either at periodic intervals or retained as resident experts for continual improvement (Forging & Foundry)
New Industrial Township under development beholds high potential for units intending to expand
DIC has commissioned a survey of all industries in Faridabad by Mott Mc Donald. The data from the survey can be a good planning tool for sectoral interventions for energy management
Improved connectivity by the Delhi Metro to increase the availability of skilled manpower from Delhi
The recently inaugurated Kundli-Manesar-Palwal (KMP) expressway is expected to ease the connectivity issues bypassing the congested routes of Delhi
<b>Threat</b>
High competition to deliver at low cost amongst the several auto units present in Faridabad
Auto industry has its inherent monthly variation in demand causing variation in orders for SME units
Metal finishing units, being the last item in the complete production chain tend to face tight schedules to deliver the item to the OEM
Rate of increase price of PNG against conventional fuels like Diesel, FO etc has been a concern for existing customers
Poor infrastructure conditions in Faridabad has forced several entrepreneurs to reside in Delhi leaving lesser time for them to deal with issues
Erratic power supply, dependence on DG power and rising cost of diesel
Over dependence on a few OEMs

There is a good opportunity for energy cost reduction in the more energy intensive units. However the priorities of the units will have to be considered while proposing energy management interventions which do not necessarily have to flow with the schedule of this assignment and hence may pose a problem with implementation of activities as per terms of reference.

## 1. ABOUT THE PROJECT

### 1.1 PROJECT OVERVIEW

Small Industries Development Bank of India (SIDBI) and Bureau of Energy Efficiency (BEE) are jointly implementing a Global Environment Facility (GEF)/World Bank funded project, which aims at promoting energy efficiency in Micro, Small and Medium Enterprises (MSMEs) in five clusters viz Ankleshwar Gujarat), Faridabad (Haryana), Kolhapur (Maharashtra), Pune (Maharashtra) and Tirunelveli (Tamil Nadu).

Development Environenergy Services Limited (DESL) has been assigned to provide project development support for two of the aforementioned clusters- Faridabad and Tirunelveli.

### 1.2 PROJECT OBJECTIVE

The objective of the World Bank funded project is to

- To create increased demand for EE investments by adopting a cluster approach to facilitate the development of customized EE products and financing solutions in five targeted industry clusters, and to build the capacity of identified apex organizations to assist MSME units in identifying additional EE projects in the future thereby aiding in widespread replication.
- To raise the quality of EE investment proposals from a technical and commercial perspective , and thus to increase the capacity of both the project developers and bank loan officers/ branch managers to help shrink the gap between project identification and successful delivery of commercial finance.
- To expand the use of guarantee mechanisms for better risk management by banks to catalyze additional commercial finance for energy efficiency
- To establish a monitoring and evaluation system for targeted clusters.

### 1.3 MAJOR COMPONENTS AND ACTIVITIES OF THE PROJECT

For meeting the overall objectives stated above, SIDBI has engaged the services of DESL for carrying out the following

- To conduct walk through energy audits of a minimum of 400 MSME units in order to assess the feasibility of cost effective low/medium investment oriented energy efficiency projects in the Faridabad and Tirunelveli clusters
- To provide information to MSME's, Financial Institutions and allied stakeholders on the scope for enhancement in energy efficiency through
- Preparing an investment grade detailed project report for the MSME unit to help obtain loan for implementation, if the unit so desires
- Implementation support to the unit including procurement support, assistance as may be required for implementing the selected energy cost reduction measures, measurement and verification of actual savings

## 2. METHODOLOGY

### 2.1 METHODOLOGY ADOPTED FOR DATA COLLECTION INCLUDING SOURCE OF DATA AND VERIFICATION IN CLUSTER

The industrial cluster in Faridabad is of mixed type and the evolution dates back to the 1950s & 1960s, and identifies its beginnings with service requirements of larger industrial units like Eicher, Escorts, Bata etc. which were initially set up. The various dimensions that thus crop in for preparing ourselves for the various supply side, demand side & technological measures for energy efficiency that need to be kept in mind while designing the data collection methodology are shown in the following figure:

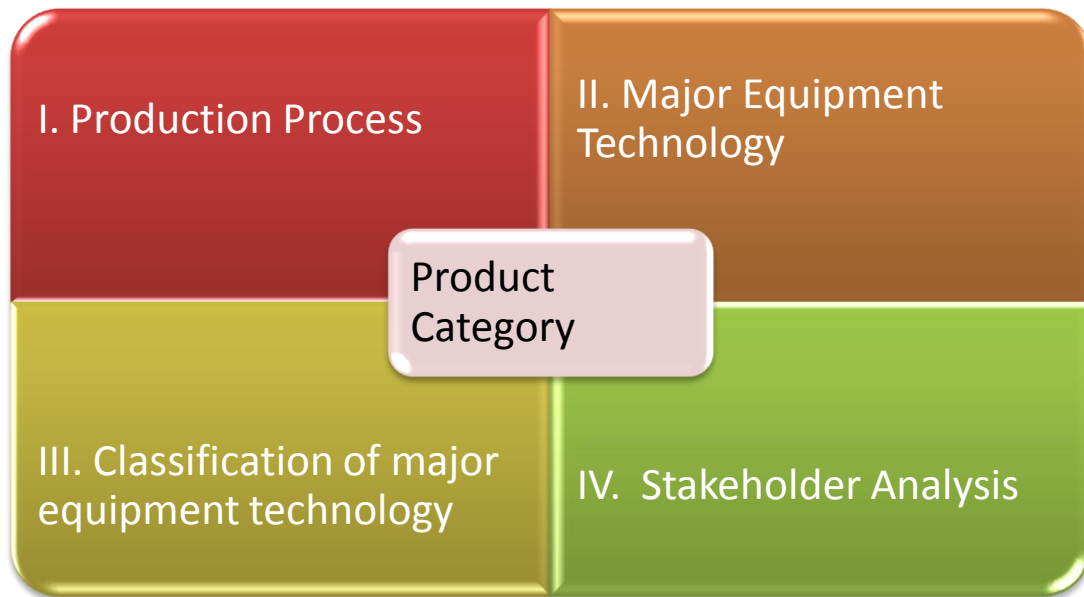

Figure 1 Dimension of information to be collected

An illustrative example about the above mentioned dimensions can be understood from the following diagram:

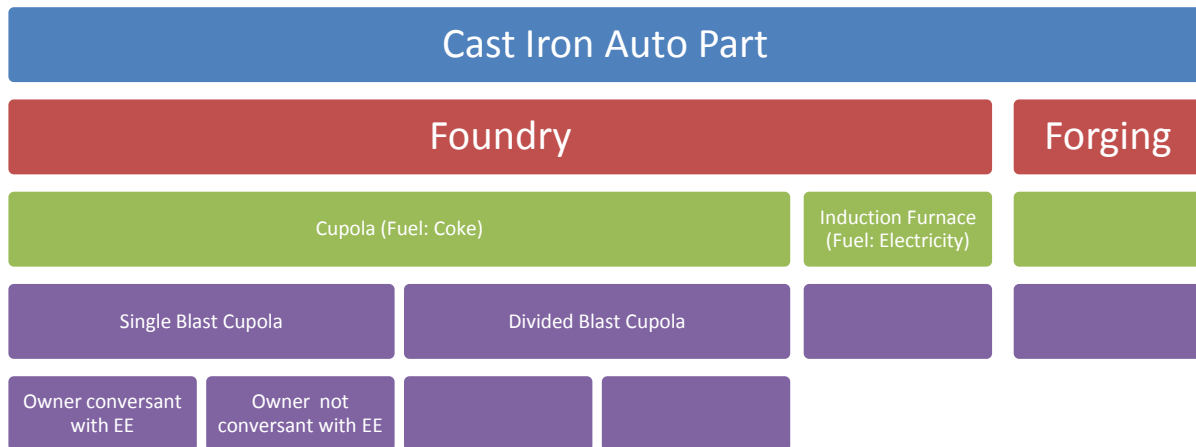

Figure 2 Example of dimensions of information to be collected

The following chart shows the methodology followed for gathering data:

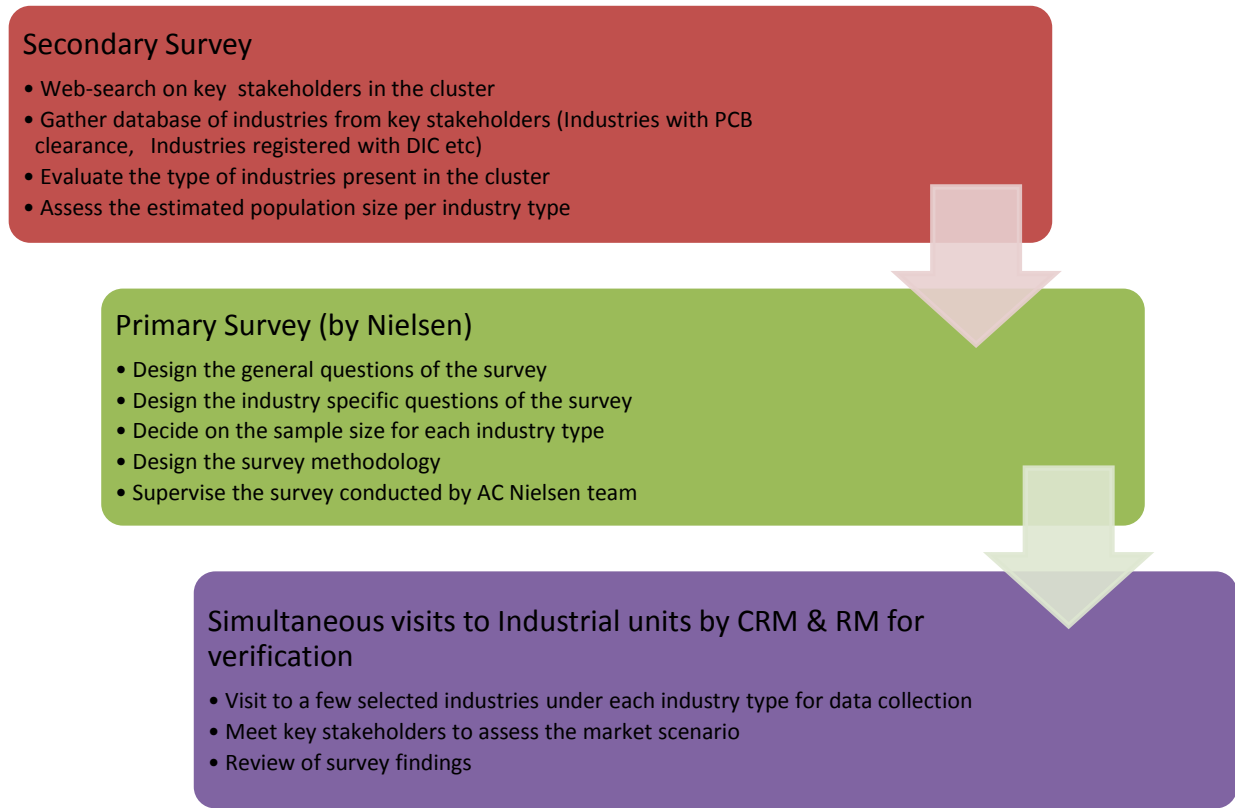

Figure 3 Methodology for gathering data

The list of key stakeholders visited during the study is as follows:

Table 4 List of key stakeholders visited by DESL

S.No	Name of Organisation	Role in the Cluster	Type of database	Details of meeting
1	District Industries Centre (DIC)	Centre for registration of Industrial Units, Promotional activities for entrepreneurs like market surveys, techno economic and managerial consultancy services	List of registered units	Several Meetings
2	Dakshin Haryana Bijli Vitran Nigam (DHBVN)	Local electricity distribution licensee or local power utility in Faridabad	-	Several Meetings
3	Haryana Pollution Control Board (HPCB)	Authority to provide clearance on the pollution front i.e. Consent to Operate (CTO)	List of industries with CTO	18 July 2012
4	Adani Gas Ltd (AGL)	Local City Gas Distribution (CGD) licensee or local gas supply utility	Database of units in Faridabad	11 July 2012
5	Small Industries Development Bank of India (SIDBI)	Financing body facilitating the growth of MSME units	Industrial client base in Faridabad	20 July 2012

S.No	Name of Organisation	Role in the Cluster	Type of database	Details of meeting
			who have availed loans for Energy Efficiency projects in the past	
6	Syndicate Bank	Commercial Bank active in Faridabad	Industrial client base in Faridabad who have availed loans in the past	31 July 2012
7	State Bank of Hyderabad (SBH)	Commercial Bank active in Faridabad	Names of a few industrial clients in Faridabad	10 Sept 2012
8	Faridabad Small Industries Association (FSIA)	Industries Association in Faridabad specifically for the small industries	Members Directory	Several Meetings
9	Faridabad Industries Association (FIA)	Industries Association in Faridabad	Members Directory	19 Sept 2012
10	Manufacturers Association (MAF)	Industries Association in Faridabad for only the manufacturing sector	Members Directory	19 Sept 2012
11	DLF Industries Association (DIA)	Industry Association for the DLF industrial area	Members Directory	19 Sept 2012

Information available at the beginning of the survey included a) databases of some of the industry associations b) a list of industries in Faridabad as per a survey commissioned by the DIC in Faridabad c) List of clients of some of the banks. In addition to the above, the report prepared by IamSME of India, was also available and served as the starting point for design of the survey.

The sample size was designed keeping in mind the heterogeneous nature of Faridabad cluster. Industrial segment wise sample was designed keeping in mind the purpose of the study, and hence with due importance to selecting larger number of industries in the more energy intensive categories. The sample size was selected to cover all industry segments as indicated in the following table:

Table 5 Industrial segments in Faridabad with Population Size and Sample Size

S.No	Industrial Segment	Population Size <sup>2</sup>	Adjusted Population Size <sup>3</sup>	Sample Size for primary survey
1	Automobile & Auto parts	1875	4256	10

<sup>2</sup> "Report on Capacity Building of Industry Association and MSME units for Faridabad mixed cluster" by IamSME of India

<sup>3</sup> Pro-rata population size with respect to the registered industries with DIC i.e. 17,186 for 20 Industrial segment (figures mentioned for only 15 industrial segments in table, excluding the segments with meager energy usage)

S.No	Industrial Segment	Population Size <sup>2</sup>	Adjusted Population Size <sup>3</sup>	Sample Size for primary survey
2	Casting	250	567	35
3	Chemicals/Paint/Powder	100	227	35
4	Die Casting	72	163	35
5	Electroplating	375	851	35
6	Fabrication	600	1362	10
7	Forgings	100	227	35
8	Heat Treatment	50	113	35
9	Industrial Fasteners	300	681	10
10	Foundry	150	340	35
11	Plastic/Plastic Products	175	397	35
12	Railway Equipment	200	454	10
13	Rubber Products	250	567	35
14	Sheet Metal Components	750	1702	10
15	Textile & Readymade garments	100	227	35
	Total	5347	12136	400

Due importance to the statistical significance of the survey was considered and the sample of 400 gives 95% confidence level and 5% margin of error on an overall basis. Simply speaking this means that any data reported for Faridabad cluster as a whole will return same values 95 out of 100 times the survey is carried out. 5% margin of error implies any data value reported for Faridabad cluster as a whole will deviate only 5% in either direction. It is also important to note that the confidence level and error of margin is applicable to findings of Faridabad Cluster as a whole and not for specific industry clusters. The questionnaire used by AC Nielsen for primary survey has been attached as Annex 1. The list of units covered under the survey is included as Annex-2.

## 2.2 CLUSTER LEVEL WORKSHOP

As part of the launch activity for the project, DESL organized an exhibition on the project at the Annual General Meeting of the Faridabad Small Industries Association (FSIA) which was held on 24<sup>th</sup> July-12, with participation of over 500 members of the FSIA. The chief guest of the event the Hon'ble Mr. BS Hooda, Chief Minister of Haryana visited the exhibit and was apprised of the SIDBI project in Faridabad MSME industries. 6 industries signed up for walk through assessments during this event.



Hon'ble Chief Minister of Haryana being apprised of the project at the Project Launch Workshop (FSIA AGM)



DESL team at the exhibition

### 3. CLUSTER SCENARIO

#### 3.1 OVERVIEW OF CLUSTER

Faridabad, the largest city in the state of Haryana, is well known as an industrial city in India. In this chapter, we would be providing an overview of the industrial cluster in Faridabad.

#### GEOGRAPHICAL LOCATION

Faridabad, one among the 21 districts in the state of Haryana is situated in the South East corner, is 25 km from Delhi in the Southern direction. Faridabad is bounded by Union Territory of Delhi (National Capital) on its north, Palwal District in the south, Gurgaon District on the west and State of Uttar Pradesh on its east. The river Yamuna separates the district boundary on eastern side with UP State.

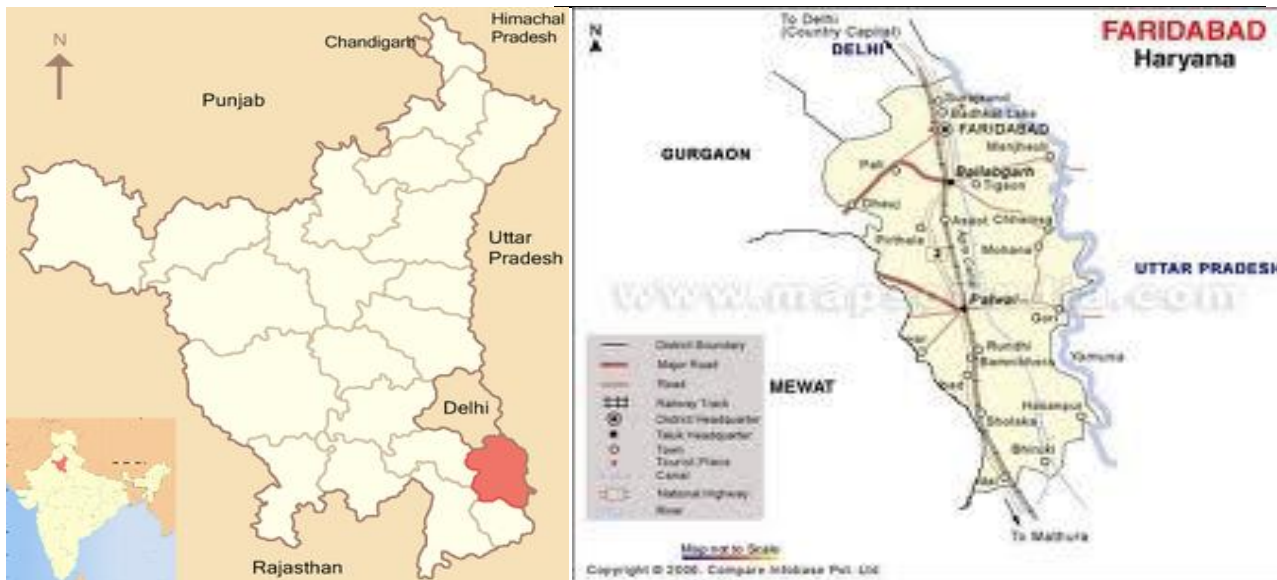

Figure 4 Map of India, Haryana State and Faridabad

The strategic location of Faridabad can be understood by the fact that it is only 25 km away from Delhi, the capital of the country. Faridabad is well connected with other parts of the country by Rail and Road. The connectivity by road has been mainly by the Delhi-Agra National Highway No.2 (Shershah Suri Marg, NH2), which passes through centre of District and by rail is by the Delhi-Mathura triple track broad-gauge line of the Indian Railway. There are three railway stations (viz. Faridabad Main, New Town and Ballabgarh) in Faridabad. Faridabad is flanked by River Yamuna in the east and the Aravali Hills in the west and south-western parts.

## HISTORY AND EVOLUTION

Faridabad came on the map of Haryana on 15th August, 1979 as the 12th District of the state, carved out from the erstwhile Gurgaon district<sup>4</sup>. Historically, Faridabad is said to have been founded by Sheikh Farid (Baba Farid), a Sufi saint, who was the treasurer of Jahangir, in the year 1607AD, to protect the Grand Trunk Road that passed through the town. Sheikh Farid had built a fort, a tank and a mosque in Faridabad which are more or less in dilapidated condition at present. Faridabad became the headquarters of a province ruled by the Ballabgarh ruler. Faridabad was a part of a post-independence resettlement project and it was the resettled population who initiated the industrial development projects of the city in the 1950s.

The growth of registered industrial units with the Directorate of Industries (DIC) in Faridabad from 1984-85 till 2010-11<sup>5</sup> can be seen from the following figure.

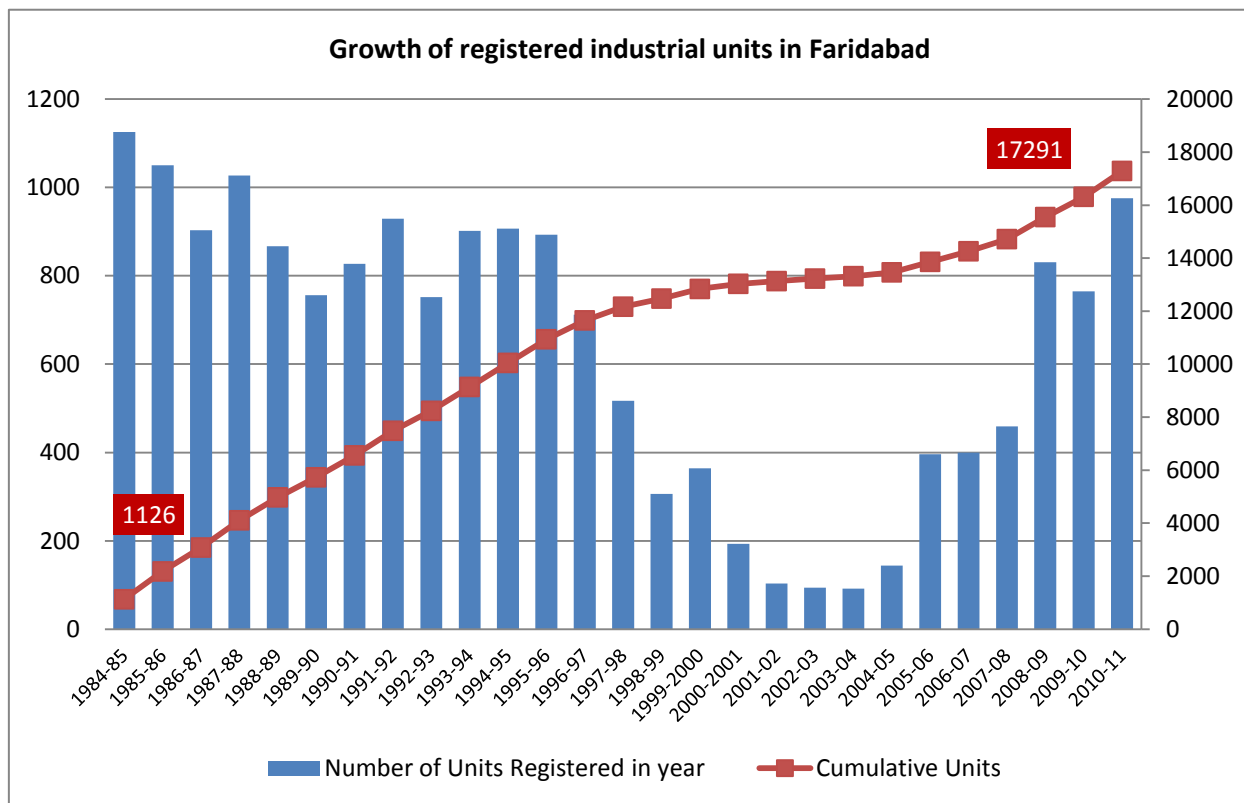

Figure 5 Growth of registered industrial units in Faridabad

<sup>4</sup> [http://faridabad.nic.in/dist\\_profile.htm](http://faridabad.nic.in/dist_profile.htm)

<sup>5</sup> "Brief Industrial Profile of Faridabad District 2012-13" by the MSME Development Institute, MSME



The evolution of the MSME units in Faridabad is said to have spurred due the setting up of big industries in the field of auto parts, tractors, shoes etc. Big names like Escorts for tractors set up their establishment in 1961<sup>6</sup>, Eicher for tractors set up in the year 1959<sup>7</sup>, Wearwell Cycle Co. set up in the year 1953<sup>8</sup>, Bata in the year 1951<sup>9</sup> etc. The sudden increase in the number of units registered from 2006-07, is attributed to the following:

- The enactment of the MSME Development Act in 2006
- The signing of MOU between the Govt. of Japan & Govt. of India for the Delhi-Mumbai Industrial Corridor project in 2006

Due to the above historical reasons, Faridabad has developed rapidly as a light engineering industrial cluster.

#### INVENTORY OF UNITS WITH CAPACITY/AGE IN TERMS OF SCALE

Out of the 400 units covered under the primary survey, there are 152 units in the micro scale, 234 units in the small scale, 11 units in the medium scale, 1 unit in the large scale and 2 units which did not respond to this question.

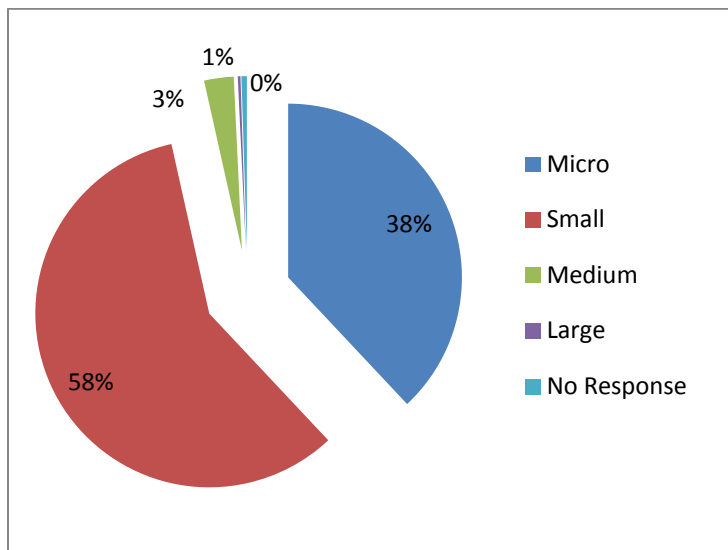

Figure 6 Scale of units in Faridabad

The survey indicates that majority of the MSME units (58%) in Faridabad are Small, followed by Micro (38%) and Medium (just 3%). Extrapolating the number of units scale-wise would give the following numbers for the whole of Faridabad cluster.

- Medium Units: 364
- Small Units: 7,039
- Micro Units: 4,612

<sup>6</sup> <http://www.escortsgroup.com/the-group/the-history-of-escorts.html>

<sup>7</sup> <http://www.eicher.in/eichergroup-heritage.aspx>

<sup>8</sup> <http://www.indiankanoon.org/doc/185711/>

<sup>9</sup> <http://www.bataindia.com/corporate.htm>

Among the MSME units interviewed, the following graph shows the pattern of the development of the units with reference to the year of establishment:

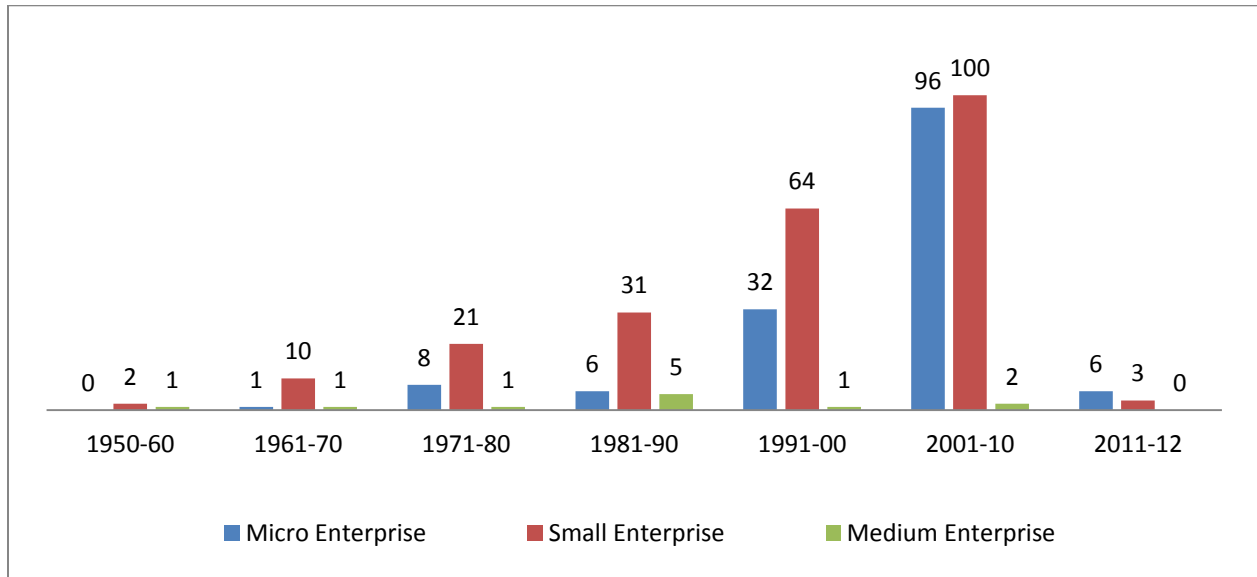

Figure 7 Year of establishment of units by scale

A random verification of the consistency of the survey results was done by comparing the results of the survey and the actual figures available for the no. of units based on year of establishment. The results were found to be quite consistent except for the category 2001-10.

The ownership pattern of MSME units from the results of the primary survey show that majority of the units (63%) are Sole Proprietorships, followed by 24% as private limited companies, 9% as Partnerships and 3% as public limited . 1% did not respond

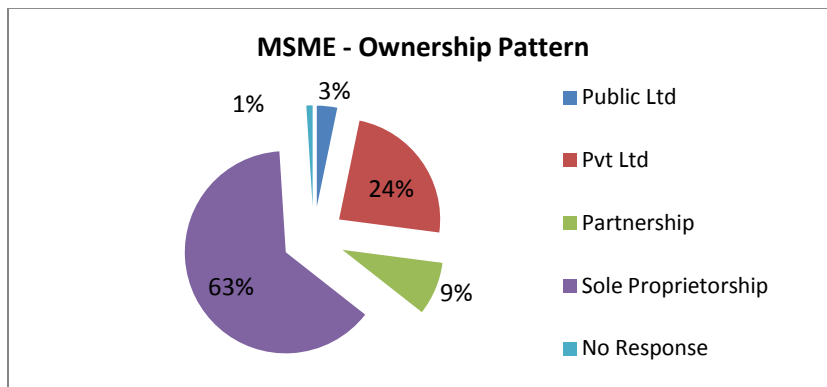

Figure 8 MSME Units - Ownership Pattern

Extrapolating the ownership pattern would give the following numbers for the whole of Faridabad cluster.

- Sole Proprietorship Companies: 7,646
- Private Ltd Companies: 2,913
- Partnership Companies: 1092

- Public Ltd Companies: 364

The scale wise ownership pattern shows that Micro Enterprises in Faridabad exist primarily as sole proprietorships, whereas small enterprises equally sole proprietorships and private limited companies. Medium enterprises are primarily private limited companies.

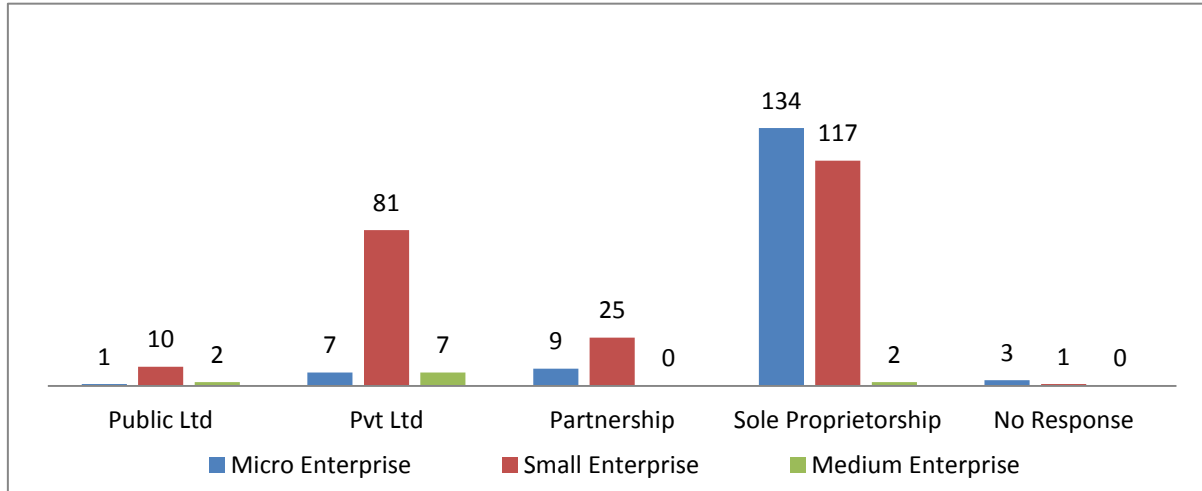

Figure 9 Ownership pattern scale-wise

The awareness about Energy Efficiency machines/equipments was also covered through the survey and the figure below shows the results. The results portray the fact that the awareness increases with the scale except for medium scale units. However, none of the Medium Enterprises confirmed any investment to have been made in EE equipments. 11 Respondents from the Small Enterprises confirmed EE investments to have taken place with the most established EE solutions like CFL in lighting, Automatic Power Factor Correction, use of CNC machines etc.

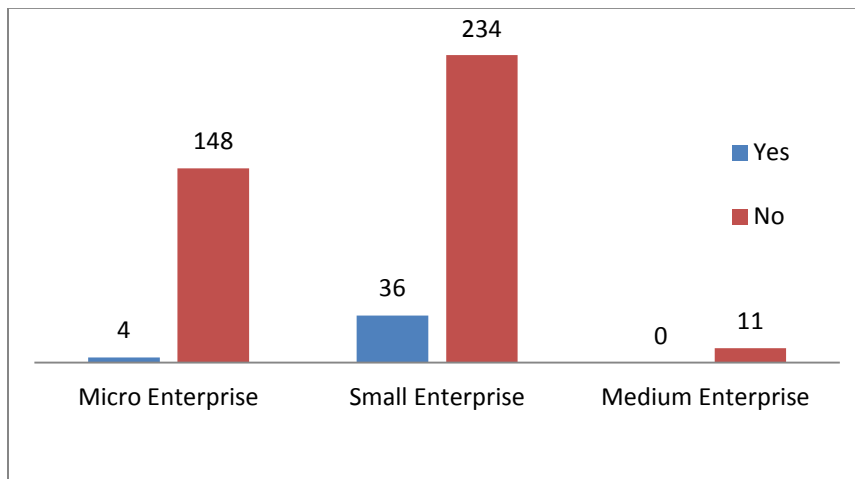

Figure 10 Are MSMEs aware of EE equipments/machines?

## RAW MATERIAL USED & PRODUCTS MANUFACTURED IN CLUSTER

The nature of raw materials used depends on the industry and the type of product being manufactured. The following table covers both the aspects of raw material used and products manufactured in each industry category:

Table 6 Raw Material Used & Products Manufactured

S No	Industry Segment	Major Raw Material Used in the cluster (excl. Energy)	Products manufactured in the cluster
1	Automobile & Auto parts	Metal Sheets of different gauges	Spring Leaves, Clutch Plates, Steel Tubes, Bumpers and all kinds of metal auto parts
2	Casting	Metal Scrap	Gear shifter assembly, Brake drums, Front wheel hubs, electric motor parts, gear boxes etc
3	Chemicals/Paint / Powder	Resin, Pigments and Oils	Detergent Soap, Paints, agro chemicals, Industrial lubricants, varnishes etc
4	Die Casting	Aluminium Ingots & Metal Scrap	Electric Motor Stampings, Fan Parts, LPG Regulator, Steel Gear Assembly etc
5	Electroplating	Chemicals, as consumables	Job work for electroplating all kinds of auto parts
6	Fabrication	Metal Sheets of different gauges	Cranes, Fans, Exhaust Systems, Heat Exchanger etc
7	Forgings	Iron Rods	Machine Parts of Automobiles
8	Heat Treatment	Chemicals & gases, as consumables	Job work for heat treatment of all kinds of auto parts
9	Industrial Fasteners	Steel Strips, Mild steel wires etc	Machine Tools, Wires, Nuts, Bolts, Brake Pedals etc
10	Foundry	Cast Iron scrap, Manganese, Silica, Pig Iron	Motor Casing, Fly Wheels, motor disc brakes, springs etc
11	Plastic/Plastic Products	Plastic pellets	PVC Pipe, Electric meter parts, Household electronic parts, small plastic auto parts etc
12	Railway Equipment	Steel Strips, Mild steel wires etc	Elastic rail clips, Railway cabinets, Moulding tools, Railway track fasteners
13	Rubber Products	Raw Rubber & Chemicals	Foot wear, Jacket, Conveyor Belt, Rubber rollers, cutting knife, rubber auto parts etc
14	Sheet Metal Components	Metal Sheets of various gauges	Metal parts of automobiles like washers, clutch plates etc; Metal parts of Washing Machines etc
15	Textile & Readymade garments	Yarn or Fabric	Garments, Cloth Dyeing etc

## TECHNOLOGICAL UPGRADES UNDERTAKEN BY UNITS IN THE RECENT PAST

Out of 400 units surveyed during the study, 334 units had invested in plant/machinery in last 5 years.

Table 7 Percentage of units who had invested in the last 5 years

Invested in last 5 years	% of units surveyed
Yes	83.5%
No	16.5%

We note that out of 157 micro units, 106 units had invested in last 5 years. In small enterprise units, 220 units out of 232 units had invested in their respective units in last 5 years. In medium enterprises, 8 out of 11 units covered in survey had invested in last 5 years in their units.

Table 8 Break-up of units invested in the last 5 years

Unit Type	Number of units covered in the survey	Number of units which have invested in last 5 years	% of units which have invested in last 5 years
Micro	157	106	67.5
Small	232	220	94.8
Medium	11	8	72.7

68% of micro units had invested in their plants while 95% of surveyed small units had invested in their plants in the last 5 years. Sectoral analysis of the investment done by units in the recent years has been highlighted in the following table:

Table 9 Sectoral analysis of pattern of investments in the past 5 years

S No	Industry Segment	No of units surveyed	No of units reporting investment in the last 5 years	Units with Single Sourcing (% of sample size)	Break-up of sources	Units with Multiple Sourcing (% of sample size)	Break-up of sources
1	Automobile & Auto parts	15	13 (87%)	11 (73%)	Self-4, Bank-6, MFI-1	2	Self, Bank & SIDBI
2	Casting	35	32 (91%)	26(81%)	Self-21 & Bank-5	6	Primarily Self & Bank; SIDBI included in 1
3	Chemicals/Paint/Powder	39	26(67%)	20(51%)	Self-16 & Bank-4	6	All Self & Bank; SIDBI not included
4	Die Casting	33	22(67%)	11(33%)	Self-10 & Bank-1	11(33%)	Primarily Self & Bank; SIDBI included in 4
5	Electroplating	36	32(89%)	8(22%)	Self-4 & Bank-4	25(69%)	Primarily Self & Bank; SIDBI included in 1
6	Fabrication	19	10(53%)	7(37%)	Self-4 & Bank-3	4(21%)	Primarily Self & Bank; SIDBI included in 1

S No	Industry Segment	No of units surveyed	No of units reporting investment in the last 5 years	Units with Single Sourcing (% of sample size)	Break-up of sources	Units with Multiple Sourcing (% of sample size)	Break-up of sources
7	Forgings	31	30(97%)	24(77%)	Self-19 & Bank-5	4(13%)	All Self & Bank; SIDBI not included
8	Heat Treatment	23	21(91%)	14(61%)	Self-8 & Bank-6	7(30%)	All Self & Bank; SIDBI not included
9	Industrial Fasteners	12	7(58%)	5(42%)	Self-2 & Bank-3	3(25%)	SIDBI not included
10	Foundry	29	28(97%)	23(79%)	Self-22 & Bank-1	5(17%)	All Self & Bank; SIDBI not included
11	Plastic/ Plastic Products	33	30(91%)	22(67%)	Self-17 & Bank-5	8(24%)	All Self & Bank; SIDBI not included
12	Railway Equipment	9	9(100%)	7(78%)	Self-3 & Bank-4	2(22%)	Self & Bank-1; SIDBI included in 1
13	Rubber Products	35	30(86%)	23(66%)	Self-17 & Bank-6	7(20%)	All Self & Bank; SIDBI not included
14	Sheet Metal Components	22	17(72%)	13(59%)	Self-5 & Bank-8	4(18%)	Self & Bank-3; SIDBI included in 1
15	Textile & Readymade garments	34	27(79%)	20(59%)	Self-15 & Bank-5	7(21%)	Primarily Self & Bank; SIDBI included in 1

Details of technology upgrades which have been implemented in some of the units are provided in Table 36.

## CURRENT MARKET SCENARIO

The current market scenario of the industry segments in Faridabad can be assessed by the outlook of the industries they cater. Analysis of the top 5 products manufactured by the 400 units covered under the primary survey and various interactions in the cluster helps us in listing the various industries the cluster which are catered by the cluster. The following table shows the major sectors covered, sectoral outlook and the relevant industry segments:

Table 10 Current Market Scenario of industrial sectors

Sectors	Sector Outlook	Relevant Industry Segments
<b>Automobile</b>	<ul style="list-style-type: none"> <li>• India is the <ul style="list-style-type: none"> <li>○ Largest manufacturer of tractors</li> <li>○ Second largest manufacturer of two wheelers</li> </ul> </li> </ul>	Automobile & Auto parts, Casting, Die Casting,

Sectors	Sector Outlook	Relevant Industry Segments
	<ul style="list-style-type: none"> <li>○ 5th largest manufacturer of commercial vehicles</li> <li>○ 4th largest passenger car market in Asia.</li> <li>● In 2012-11, India was the 6th largest vehicle manufacturer globally.</li> <li>● At present, there are 19 manufacturers of passenger cars &amp; multi utility vehicles, 14 manufacturers of commercial vehicles, 16 of 2/3 wheelers and 12 of tractors besides 5 manufacturers of engines in India. This includes virtually all the major global Original Equipment Manufacturers (OEMs) and also home grown companies<sup>10</sup>.</li> <li>● With a CAGR of over of 15% during the last 5-7 years, the automotive sector is aptly described as the next sun rise sector of the Indian economy<sup>10</sup>.</li> <li>● In 2020, the market for commercial vehicle and two wheelers in India is expected to reach 2.7 million and 30 million respectively, thereby making India the third largest vehicle market in the world. This will translate into an overall industry turnover of USD 162 billion, with the component industry attaining a turnover of USD 113 billion<sup>10</sup>.</li> <li>● The list of OEMs served by the industrial units in Faridabad are Escorts, Mahindra, Eicher, Yamaha, Maruti, Honda Siel Cars, New Holland etc who provide a steady opportunity to the units in Faridabad</li> <li>● The automobile market has been slow due to the following reasons <ul style="list-style-type: none"> <li>○ Rising price of petrol and diesel</li> <li>○ Rising interest rates</li> <li>○ Interruption in the production at Maruti, Manesar plant</li> </ul>           However, these reasons are perceived to be of short term nature         </li> </ul>	Electroplating, Fabrication, Forgings, Heat Treatment, Industrial Fasteners, Foundry, Rubber Products & Plastic/Plastic Products (10 out of 15 Industrial Segments present in Faridabad)
<b>Construction</b>	<ul style="list-style-type: none"> <li>● Faridabad has been one of the oldest industrial clusters in India and houses the next generation industrialists. The journey of no of registered industries from 1,126 in 1984-85 to 17,291 in 2010-11 has developed several equipment/machinery manufacturers in Faridabad</li> <li>● The upcoming Industrial Model Town (IMT) developed by HSIIDC with about 500 industrial plots is another potential market for the industries in the segment</li> <li>● The list of OEMs served by the industrial units in Faridabad are JCB, Bharatia Cutler Hammer, ABB, Hyderabad Industries Ltd., Tecumseh India P. Ltd. etc</li> </ul>	Fabrication, Rubber Products, Foundry, Industrial Fasteners and Sheet Metal (5 out of 15 Industrial Segments present in Faridabad)
<b>Domestic Products</b>	<ul style="list-style-type: none"> <li>● Faridabad being a part of the National Capital Region (NCR), the population density is very high. Thus demanding all kinds of home appliances, consumable items</li> <li>● The variety of products manufactured are very high and thus provide flexibility to the units to maintain steady business</li> </ul>	Plastic/Plastic Products and Textile & Readymade garments (2 out of 15 Industrial

<sup>10</sup> Report of the Working Group on Automotive Sector for the 12<sup>th</sup> Five Year Plan (2012-17)

Sectors	Sector Outlook	Relevant Industry Segments
	<ul style="list-style-type: none"> <li>The list of OEMs served by the industrial units in Faridabad are Whirlpool, Bata, Lakhani, Hindustan Wires Ltd, Sun Flame, Bharat Foam Udyog etc</li> </ul>	Segments present in Faridabad)

## CLUSTER LEVEL TURNOVER AND EMPLOYMENT

The cluster level turnover and employment has been estimated with the help of the results of the primary survey. Though the sizes of the samples for individual industry segments are not significant for proper statistical extrapolation, the data has been used to arrive at the estimated turnover and employment at a cluster level.

**Table 11 Cluster Level Turnover and Employment**

S No	Industry Segment	Sample Size	Average Turn Over (Lakh Rs)	Population Size	Cluster Level Turnover (Lakh Rs)	Average employment (Permanent)	Average employment (Contract)	Cluster Level Employment (Permanent + Contract)
1	Automobile & Auto parts	15	737	4,256	31,36,672	46	23	2,93,664
2	Casting	35	455	567	2,57,985	21	10	17,577
3	Chemicals/Paint/ Powder	29	295	227	66,965	14	7	4,767
4	Die Casting	33	675	163	1,10,025	26	27	8,639
5	Electroplating	36	3696	851	31,45,296	31	18	41,699
6	Fabrication	19	737	1362	10,03,794	29	26	74,910
7	Forgings	31	771	227	1,75,017	26	34	13,620
8	Heat Treatment	23	1172	113	1,32,436	40	72	12,656
9	Industrial Fasteners	12	482	681	3,28,242	38	41	53,799
10	Foundry	29	106	340	36,040	13	17	10,200
11	Plastic/ Plastic Products	33	1386	397	5,50,242	29	66	37,715
12	Railway Equipment	9	166	454	75,364	23	6	13,166
13	Rubber Products	35	608	454	2,76,032	28	20	21,792



S No	Industry Segment	Sample Size	Average Turn Over (Lakh Rs)	Population Size	Cluster Level Turnover (Lakh Rs)	Average employment (Permanent)	Average employment (Contract)	Cluster Level Employment (Permanent + Contract)
14	Sheet Metal Components	22	637	1702	10,84,174	38	79	1,99,134
15	Textile & Readymade garments	34	1271	227	2,88,517	97	146	55,161
<b>Total</b>		<b>395</b>			<b>106,66,801</b>			<b>8,58,499</b>

## SOCIAL AND ENVIRONMENTAL ASPECTS IN THE CLUSTER

### Social Aspects

The social practices in the cluster involve the employment of huge manpower in the industries, which boosts the employment of the local people too. Further, it was found that around 15% of the employees are female. The industry specific employment of male-female employees in each of the industry segment, arrived by calculating the average of the samples available in each industry, is as shown in the following figure:

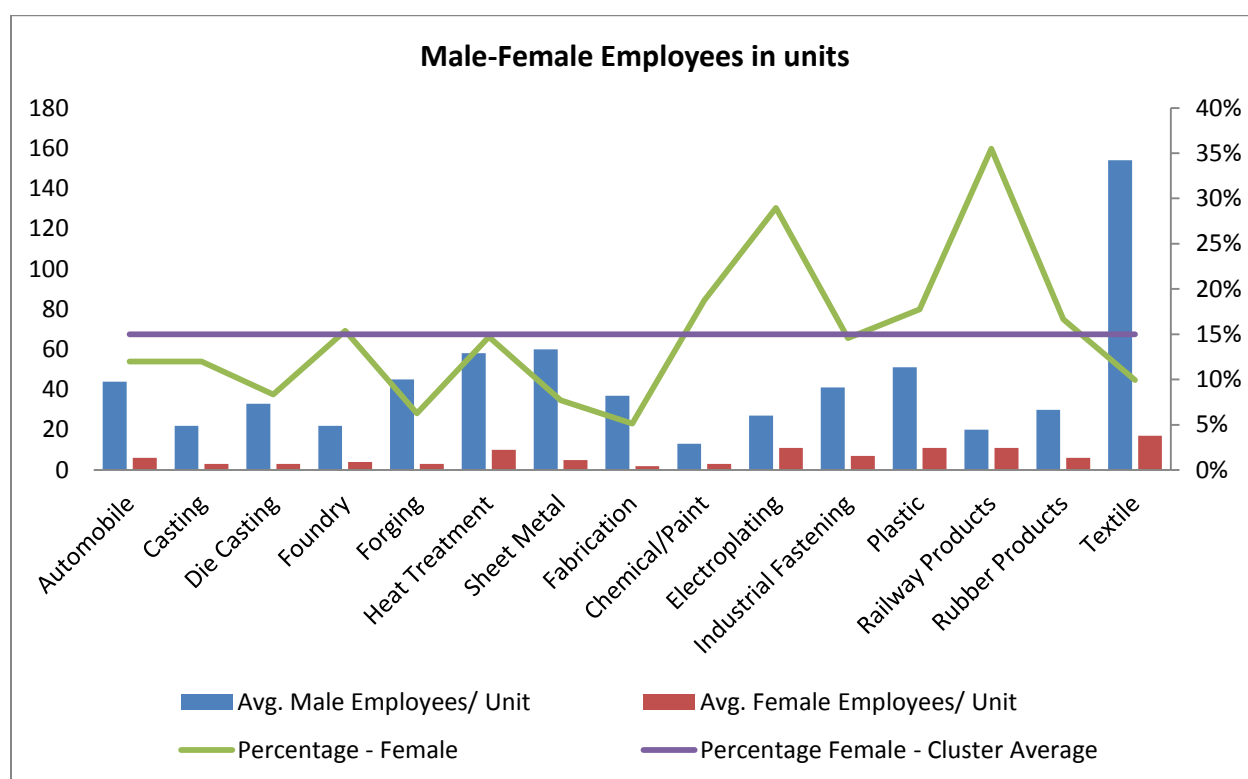

Figure 11 Male-Female employees in units

## Environmental Aspects

The Central Pollution Control Board (CPCB) had conducted a study to evaluate the current status of environmental components such as air and water quality data, ecological damage and visual environmental conditions in 2009. The study reviewed 88 industrial clusters including Faridabad and ranking was done based on an index known as “Comprehensive Environmental Pollution Index (CEPI)”. Faridabad Industrial cluster was ranked as the 18<sup>th</sup> most polluting cluster among the 88 clusters in India. The figures for three clusters The most polluting cluster (Ankleshwar, Rank #1), Faridabad (Rank #18) & the least polluting cluster among the 88 selected clusters (Digboi Rank #88) are as follows:

Table 12: CEPI values for Faridabad

Parameter	Faridabad Scores* (18 <sup>th</sup> Rank)	Ankleshwar Scores* (1 <sup>st</sup> Rank)	Digboi Scores* (88 <sup>th</sup> Rank)
<b>Air Environment</b>	63.50	72.00	32.00
<b>Surface Water</b>	59.00	72.75	32.75
<b>Land (Soil &amp; Groundwater)</b>	62.75	88.50	38.00
<b>CEPI</b>	77.07	88.50	44.55

\* Scores out of 100

Faridabad has been declared as one of the Critically Polluted Industrial Cluster under the study. Further, the observations from the ongoing energy efficiency project

- DESL has been collecting the “Consent to Operate (CTO)” certificate from industrial units participating in the project. However, units from the non-conformity area tend to be facing problem with obtaining the CTO certificate especially for the cupola based foundry units.
- None of the 400 units under the primary survey mentioned any problem with environmental aspects.

---

### CURRENT INITIATIVES BY LOCAL BODIES VIZ. IA, GOVT. BODIES RELATED TO MSMES

- Industry Associations like the FSIA/IamSME of India have been very active in the cluster and have been supporting the MSMEs especially in Faridabad. The host of initiatives from IamSME of India include the following:
  - Lean Manufacturing: Training & On the spot optimisation of plant processes by experts
  - Tod, Phod & Jod: On the job training of engg graduates in industrial units and motivating them to understand the existing technology & allowing them to get involved and innovate for the betterment of the unit
  - Solar Power Cluster: Tie-up with Bosch, Germany for supply of solar panels alofn with pre-sanctioned loan from SIDBI & subsidy from MNRE
  - Insurance: Providing low cost insurance solutions due to collective pre-bargained deals with insurance providers
- The MSME Development Institute, Okhla, New Delhi has prepared an industrial profile of Faridabad District with the help of the District Industries Centre (DIC), Faridabad in 2012. The profile, which includes the survey of all the industries in Faridabad, would serve as a database for proper policy making and planning for the benefit of industries in Faridabad.

- Bank of Baroda has a scheme for financing energy efficiency projects for the SMEs for acquisition of equipments, services and adopting measures for enhancement of energy efficiency/conservation of energy.
- The OEMs like Maruti, JCB and ABB are conduct training programs & productivity improvement programs in their vendor units in Faridabad

## 4. MAJOR CLUSTER ACTORS

### 4.1 INDUSTRIAL ASSOCIATIONS

Faridabad Industrial cluster, well known for the automobile and allied industries, has a geographical stretch of more than 40 km along the Mathura Road starting from the Delhi-Faridabad Border to Palwal. There have been majorly three industrial estate developers from the Haryana Government to have developed the industrial estate in Faridabad i.e. Haryana State Industrial Development Corporation (HSIDC) and Haryana Urban Development Authority (HUDA) and the Directorate of Industries (DIC). Also there are several private developers like DLF, who have carved industrial plots with suitable infrastructural facilities for the benefit of industrial development. Some of the prominent Industrial Associations in the Faridabad cluster are as follows:

Table 13 Industrial Associations in Faridabad

S.No	Name of Organization	Website	Name of Representative and Position/Role	Email	Contact Number
1	DLF Industries Association	-	Mr J P Malhotra, President	jpmalhotra@bharatvalves.com	9810012999
2	Faridabad Chamber of Commerce and Industry	<a href="http://fccionline.com/">http://fccionline.com/</a>	Mr R C Khandelwal, Hon. Gen. Secretary	fcci2002@hotmail.com; info@fccionline.com	9811081909
3	Faridabad Foundry Association	<a href="http://ffaonline.in/">http://ffaonline.in/</a>	Mr. Agarwal, General Secretary	info@ffaonline.in; faridabadfoundry@gmail.com	91-129 - 23456789, 4315284
4	Faridabad Industries Association	<a href="http://www.fia-fbd.com/">http://www.fia-fbd.com/</a>	Dr S K Goel, President	fiafbd@ndf.vsnl.net.in	0129 2232136, 2235176
5	Faridabad Small Industries Association	<a href="http://www.fsiaindia.com/">http://www.fsiaindia.com/</a>	Mr Rajive Chawla, President	fsiaindia@gmail.com	0129-2234950
6	Integrated Association of Micro, Small and Medium Enterprises of India (Iam SME of India)	<a href="http://www.iamsmeofindia.co.in/">http://www.iamsmeofindia.co.in/</a>	Mr Rajive Chawla, Chairman	iamsmeofindia@gmail.com	9711123111, 9711310585
7	Faridabad Small Scale Pollution Control Co-op. Society	-	Mr. S.S Tanwar, Past President	-	-

S.No	Name of Organization	Website	Name of Representative and Position/Role	Email	Contact Number
8	Laghu Udyog Bharati	<a href="http://lubindia.com/">http://lubindia.com/</a>	Mr Arun Bajaj, District President		0129-2232821, 2238367
9	Manufacturers Association of Faridabad	<a href="http://maf.co.in/">http://maf.co.in/</a>	Mr R Prabhakar, General Secretary	manufbd@airtelmail.in	0129-4046598
10	Faridabad Plastics Association	-	Mr C J Sachdeva, President	-	0129-2277444

#### 4.2 GOVERNMENT BODIES ASSOCIATED WITH MSMES IN THE CLUSTER

A host of Government bodies playing different roles are associated with the MSMEs in the Faridabad cluster. A few prominent names are listed in the table below:

Table 14 Government Bodies associated with MSMEs in Faridabad

S.No	Name of Organization	Website	Role
1	Dakshin Haryana Bijli Vitran Nigam (DHBVN)	<a href="http://www.dhbvn.com/">http://www.dhbvn.com/</a>	Local Power Distribution Licensee / Electricity supplying utility
2	Haryana State Pollution Control Board (HSPCB)	<a href="http://hspcb.gov.in/">http://hspcb.gov.in/</a>	State level body for seeking Consent to Operate for the industry related to environment pollution aspects
3	Haryana State Industrial Development Corporation (HSIDC)	<a href="http://www.hsiidc.org/">http://www.hsiidc.org/</a>	Industrial infrastructure development, industrial project promotion, Investment facilitation and Estate Management
4	Haryana Urban Development Authority (HUDA)	<a href="http://www.huda.gov.in">http://www.huda.gov.in</a>	Design, develop and manage urban infrastructure including industrial infrastructure
5	Directorate of Industries (DIC)	-	Design, develop and manage urban infrastructure including industrial infrastructure
6	Municipal Corporation of Faridabad (MCF)	<a href="http://www.mcfbd.org/">http://www.mcfbd.org/</a>	Local municipal corporation responsible for supplying water, draining waste water etc
7	Labour Department, Haryana	<a href="http://hrylabour.gov.in/">http://hrylabour.gov.in/</a>	Authority to check compliance on laws related to labour & fire safety by the Haryana Safety Council

#### 4.3 ACADEMIC AND R&D INSTITUTIONS

Some of the academic institutions / R&D institutions active in Faridabad are as mentioned in the table below:

Table 15 Academic and R&D Institutions in Faridabad Cluster

S.No	Name of Organization	Website	Role	What type of services provided to this cluster
1	The Institute of Indian Foundrymen (IIF)	<a href="http://www.indianfoundry.org">http://www.indianfoundry.org</a>	Promote education, research, training and development to Indian foundrymen and to serve as a nodal point of reference between the customers and suppliers of the Indian foundry industry on a global scale	Capacity Building of entrepreneurs in the foundry sector
2	Manav Rachna International University (MRIU)	<a href="http://mriu.edu.in">http://mriu.edu.in</a>	The university has several streams of engineering that serves as a research bed for the industry	Provide training to engineering students in the premises of the industrial unit for process re-engineering along with FSIA
3	Central Mechanical Engineering Research Institute (CMERI)	<a href="http://www.cmeri.res.in/">http://www.cmeri.res.in/</a>	The apex R&D institute for mechanical engineering under the aegis of the Council of Scientific and Industrial Research (CSIR )	Frequent visits to industries through FSIA with respect to process optimisation
4	Regional Labour Institute, Faridabad	<a href="http://www.dgfasli.nic.in/">http://www.dgfasli.nic.in/</a>	Industrial Safety	Training program on Industrial Safety

#### 4.4 SERVICE/TECHNOLOGY PROVIDERS

Table 16 Service/Technology Providers in Faridabad Cluster (Partial List)

S.No	Name of Organization	Contact Address	Area
1	Bajaj Electricals	1/10,Asaf Ali Road, New Delhi-2	Luminaries BU
2	Osram Electricals	Vandana Building,11,Tolstoy Marg,delhi-11	Lighting, Exclusive transformers for lighting and Ballast
3	Philips Electronics	DLF Cyber city, Gurgaon	Lighting
4	Blue Star	DLF Qutab Enclave, PhaseIII, Mehrauli Gurgaon Road	Heating, Ventilation & Air Conditioning and Refrigeration

S.No	Name of Organization	Contact Address	Area
5	Twiga Insulating	Twiga House,3 community centre, East of Kailash, New Delhi	Insulation-Glasswool
6	Schneider Electric	A-29, Mohan Cooperative Industrial Estate, Mathura Road, New Delhi-110044, India.	Control & Instrumentation and VFD
7	KSB Pumps	Pushkarna sales,Hauz Qazi,Delhi-6	Pumps and Valves
8	Forbes Marshall		Control & Instrumentation, Process efficiency, energy conservation and environment
9	Elgi Equipments	23, Shivaji Marg, Near Karampura, Opposite to DCM, New Delhi, Delhi 110 015	Air Compressors
10	Kirloskar Pumps	Jeevan Tara Building,5,Parliament street,delhi-1	Pumps
11	Honeywell electrical devices & systems India Ltd	Malviya Nagar,New Delhi	Electrical Devices & Systems, Heat Reclaim Ventilation / Air Conditioning System
12	Thermax	9 Community Centre, Basant Lok, New delhi-110057	Cooling & heating division
13	Llyod Insulation	Kalkaji Industrial Area, New Delhi	Insulation
14	Atlas Copco	Tower A,1st floor, Unitech Business Park,Block-F,Sector-41,South City-1,Gurgaon	Air Compressors & Gas
15	International Coils Limited	Naraina,Delhi-110028	Heat Exchanger, Cooling coils, VAM and Chillers
16	Thermax cooling & heating systems	Delhi	Boilers & Chillers
17	Larson & Toubro	Electrical business group,32,shivaji marg, Near moti nagar,delhi-15	Variable Frequency Drives for motors and Power Factor Improvement Products
18	ABB	Faridabad	Drives, Automatic Power Factor Controller
19	Seimens		Variable Frequency Drives for motors, Power factor improvement Products
20	Technotherm furnace	CB- 210 Basement, Ring Road, Naraina, New Delhi, India.	Oil/Gas Burners, hot air Generators, Aluminium melting furnace, Electrically heating furnace, Automatic melting furnaces, Rotary melting furnaces, digitally controlled furnaces, Bell Annealing Furnace and waste heat recovery system

## 4.5 FINANCIAL INSTITUTIONS/BANKS

There are several financial institutions / Banks providing services in Faridabad. The following tables show the details:

### LEAD BANK DETAILS

Table 17 Lead Bank in Faridabad Cluster

S.No	Name of Organization	Locations in Faridabad	No of Branches
1	State Bank of India (SBI)	Neelam Chowk, NIT, SIB, Ballabgarh (DCO) Sector-16 Market, Sarai Khwaja	6

### OTHER NATIONAL AND COMMERCIAL BANKS

Table 18 Other National and Commercial Banks in Faridabad Cluster

S.No	Name of Organization	Locations in Faridabad	No of Branches
1	Indian Overseas Bank	NIT, Sector-12, YMCA, NHPC Sec-33	4
2	Syndicate Bank	MCF, Sector-21 C, NIT, SSI, Tilpat Ballabgarh	6
3	State Bank of Patiala (SBP)	Yamaha Motors (MSD Escorts) Sector-9 Sector-11 Sector-15 Sector-24	5
4	Union Bank of India	NIT Sec-7 Badkhal	3
5	State Bank of Hyderabad (SBH)	NIT	1
6	Oriental Bank of Commerce	NIT Sector-17 Sihi – Sector-7 Sarai Khwaja NH-1 D Park Sector-19 Sector-14 Ballabgarh Sector-3 Sector-15A	10
7	Punjab National Bank	NIT NH-III (DAV College) Old Faridabad Sector-37 Sector-15 M.M.Pur Ballabgarh Jharseintly	8
8	State Bank of Bikaner and Jaipur	NIT	1

S.No	Name of Organization	Locations in Faridabad	No of Branches
9	Indian Overseas Bank	NIT Sector-12 YMCA NHPC Sec-33	4
10	Indian Bank	NIT Badarpur Sector-22	3
11	Bank of Baroda (BOB)	NIT CGO Complex NH-V 1&2 Chowk Old Faridabad	5
12	Bank of India	NIT (C) Mathura Road Ballabgarh	3
13	Bank of Maharashtra	NIT Tikona park SSI Branch (SME) Sector-9 Ballabgarh	5
14	Gurgaon Gramin Bank	NIT Old Faridabad Ballabgarh	3
15	HDFC	BK Chowk Sector-16 Sector-21C Sector-34	4
16	ICICI Bank	Sector-16 Sector-21 NIT	3

## FINANCIAL INSTITUTIONS

Table 19 Financial Institutions in Faridabad Cluster

S.No	Name of Organization	Locations in Faridabad	No of Branches
1	Haryana State Industrial Development Corporation (HSIDC)	Sector-31	1
2	Haryana Finance Corporation	NIT	1
3	Small Industries Development Bank of India	NIT	1



## 5. TECHNOLOGY USED, PRODUCTION PROCESS & TECHNOLOGY STATUS IN CLUSTER

The set of 15 industrial segments defined for the primary survey were re-organised into 10 industrial sectors based on similarity in the energy consumption pattern as shown in the table below:

Table 20 Re-organisation of sectors

S.No	Industrial Segment for primary survey	Re-organisation of sectors	Remarks
1	Automobile & Auto parts	Auto Components / Auto Ancillary	
2	Casting		Included in Foundry
3	Chemicals/Paint/Powder	Chemical / Paint	
4	Die Casting	Die Casting	
5	Electroplating	Electroplating / Powder Coating	
6	Fabrication	Fabrication	
7	Forgings	Forging	
8	Heat Treatment		Included in Electroplating/ Powder Coating
9	Industrial Fasteners		Included in Railway Products
10	Foundry	Foundry	
11	Plastic/Plastic Products	Plastic / Rubber / Packaging	
12	Railway Equipment	Railway Products	
13	Rubber Products		Included in Plastic / Rubber / Packaging
14	Sheet Metal Components		Included in Auto Components
15	Textile & Readymade garments	Textile, Apparel & Dyeing	

These ten (10) sectors were then studied in detail to present the technologies being used in the Faridabad cluster, develop process flow charts with short descriptions for the representation of a typical unit.

### 5.1 AUTO COMPONENTS / AUTO ANCILLARY / SHEET METAL

Auto Components / Auto Ancillary /Sheet Metal industries in Faridabad manufacture a variety of products like – Clutch Plates, Spring Leaves, Steel Tube, Silencer, Bumper, tractor transmission parts, valve tappets, tie rod levers , Precision Machined Component , CNC machined parts and allied items. They supply their products to the big automobile industries in Faridabad and Gurgaon. Out of the 15 units surveyed and another 10 units where WTA was conducted, most of them have expressed very low levels of export volumes primarily because of the local big automobile industries in Faridabad.

## MAJOR EQUIPMENT

Table 21 Major Equipments used in the Auto Parts

Name of Machine	Application	Energy Used
<b>Shearing Machine</b>	Cut metal sheets to desired shapes	Electricity
<b>Drilling Machine</b>	Drilling holes in the cut sheets	Electricity
<b>Bending Machine</b>	Bend the cut sheet to desired angles	Electricity
<b>Forging Furnace</b>	Hardening & Tempering of the metal shape for improving the mechanical properties	Diesel / Furnace Oil/ Piped Natural Gas
<b>Various Welding Machines</b>	Add small components to complete the desired product	Electricity
<b>Lathe Machines/ CNC Machines/Grinders</b>	Providing finishing to the product before powder coating	Electricity
<b>Hot Water &amp; Chemical Dip Tanks including Hot Water Generator</b>	Pre-treatment of the metal shape before powder coating	Diesel / Furnace Oil/ Piped Natural Gas / Electricity
<b>Powder Coating Machine</b>	Spraying of dry powder and coating the metal shape with the desired colour	Diesel / Furnace Oil/ Piped Natural Gas / Electricity
<b>Drying Oven</b>	Drying the coated metal shape using hot air for long lasting colour coat	Electricity
<b>Quality Testing</b>	Manual testing of the quality before packing and despatch	-

Out of the 15 samples of the primary survey, the majority of the machines mentioned by the industrial units in the descending order of presence are Lathe Machines, Air Compressor, Various electric motors, Grinders, Power Press, Pumps, Furnace, Shearing Machine and.

## PROCESS FLOW DIAGRAM

The following figure depicts the typical industry Process Flow Diagram (PFD) for a medium scale unit.

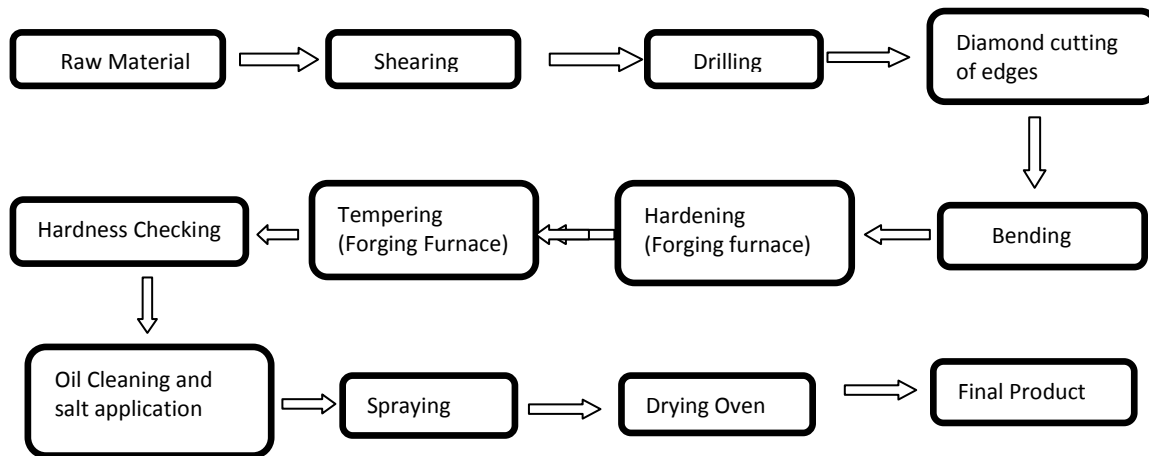

Figure 12 PFD of an Auto Components / Auto Ancillary unit

The brief description of the above mentioned process is as follows:

1. Initially the raw material undergoes shearing, drilling and cutting process to give the desired shape of the product.
2. After bending process the product is treated for improving mechanical properties by hardening and tempering
3. The improved product is sent for Oil-cleaning, Paint spraying process

## PRODUCTION CAPACITIES

The automobile manufacturing units are engaged in production of different products. The products in each of the units and the production in 2011-12 were as follows:

**Table 22 Products and Production Capacities of Units Surveyed – Auto Sector**

Unit	Product	Production
1	Tool Parts Silences	50000 Units 10000 Units
2	Steel parts for Maruti	500,000 units
3	Machines	30 machines per year
4	Clutch Plates	36000 pieces
5	Gears	216000 Pieces
6	Gears	3600 Tons
7	Casting products	2000 Tons
8	Sheet Metal Components	78000000 pieces
9	Steel Tubes	3000 Tons
10	Bumpers, Switches, Coil, Lighting Parts	1500000
11	Tractor Transmission parts	900000
12	Automobile spare parts	55000
13	Automobile parts	4000/DAY

## 5.2 CHEMICAL/PAINT

Chemical/Paint industries in Faridabad manufacture a variety of products like – Lubricants, varnish, soaps, paints and chemicals. They supply their products to the local industries and the domestic consumption in Faridabad and Gurgaon. Out of the 29 units surveyed, most of them have expressed very low levels of export volumes primarily because of the local industries in Faridabad.

## MAJOR EQUIPMENT

**Table 23 Main Process Equipment in Chemical Industries**

Name of Machine	Application	Energy Used
<b>Mixing Machine</b>	Mixing of oils with base	Electricity
<b>Drying Oven</b>	Drying the mixture in the desired shape	Electricity, Diesel
<b>Quality Testing</b>	Manual testing of the quality before packing and despatch	-

Out of the 29 samples of the primary survey, the majority of the machines mentioned by the industrial units in the descending order of presence are Air compressors, Mixer, electric motors and Oven.

## PROCESS FLOW DIAGRAM

The following figure depicts the typical industry Process Flow Diagram (PFD) for a medium scale unit.

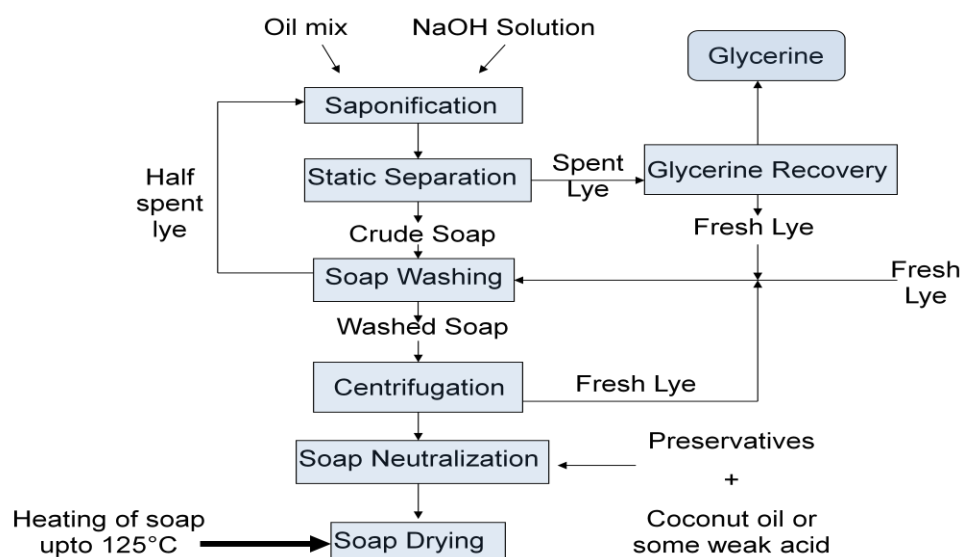

Figure 13 PFD of a soap manufacturing unit

The brief description of the above mentioned process is as follows:

1. Initially the oils are heated to 50C to maintain it in liquid form and can be pumped to the mixer
2. The oil is mixed with certain other ingredients to prepare the mix
3. The mix is poured into dies of a particular shape
4. Drying of the filled dies in oven

## PRODUCTION CAPACITIES

The manufacturing units are engaged in production of different products. The products for selected units where production data was available and the production in 2011-12 was as follows:

Table 24 Products and Production Capacities of Units Surveyed –Chemical/Paint Sector

Sl No	Product	Number of Units	Production
1	Industrial Lubricants	1	12000 Litres
	Surface Treatment Chemicals		60000 Litres
	Detergents		80000 kg
	Perfumes		24000 Litres
	Shampoos		50000 Litres
2	Powder and Paints	6	20-50T
3	Detergents	2	50 T – 20000 T
4	General industrial chemicals	8	Made to order

Sl No	Product	Number of Units	Production
5	Agro Chemicals	1	156000
6	Pharmaceutical	1	24000000 Tablets 30000 Bottles
7	Refractory Powder	1	600 Tons

### 5.3 DIE CASTING

Die casting industries in Faridabad manufacture a variety of products like – Systems and parts for Die Casting, Electrical Stamping, Aluminium Die Casting, Manufacturing, Casting of the auto and motor parts. They supply their products to the big automobile industries in Faridabad and Gurgaon. Out of the 33 units surveyed and another 1 unit where WTA was conducted, all of them have expressed zero level of export volumes primarily because of the local big automobile industries in Faridabad.

#### MAJOR EQUIPMENT

Table 25 Major Equipments used in the Auto

Name of Machine	Application	Energy Used
<b>Melting Oven/Furnace</b>	To melt the metal in the solid form to liquid state	Diesel / Furnace Oil/ Piped Natural Gas / Electricity
<b>Die Casting Machine</b>	Casting of molten metal into pre-designed die	Electricity
<b>Lathe Machines/ Machines/Grinders</b>	<b>CNC</b> Providing finishing to the product before powder coating	Electricity
<b>Quality Testing</b>	Manual testing of the quality before packing and despatch	-

Out of the 33 samples of the primary survey, the majority of the machines mentioned by the industrial units in the descending order of presence are Die Casting Machine, Melting Furnace, Lathe Machines, Various electric motors, and Grinders.

#### PROCESS FLOW DIAGRAM

Figure 14 shows the typical industry Process Flow Diagram (PFD):

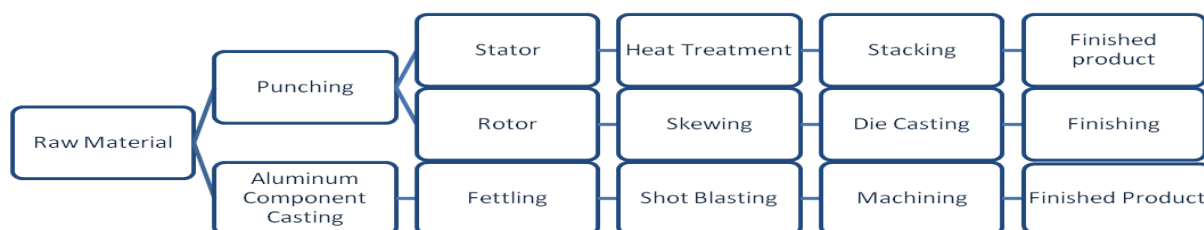

Figure 14: PFD of die casting unit

The process starts at spoolers which feed the blanking machines with sheet metal. The machine produces pieces of required design. The lamination blanked for making stator is then sent to normalizing and decarburizing furnace. From here the laminations are sent to stacking section. They are stacked together according to gauge thickness. The rotor laminations are not heat treated. They are sent to the rotor skewing section where they are arranged by gauge and held together by a bolt or a stud. After that it's sent to aluminium die casting section where electrical grade aluminium is filled in the rotor and caps the laminations. The stud holding the laminations together is separated from the rotor component.

There is a separate section for aluminium die casted pieces where liquid aluminium is die casted into desired die. The aluminium is melted in furnaces operating on natural gas.

## PRODUCTION CAPACITIES

The manufacturing units are engaged in production of different products. The methodology for reporting production varies from unit to unit, i.e.

- a) based on number of pieces of product manufactured (19 units)
- b) Based on quantity expressed in tons (7 units – 360-500 Tons per year).
- c) based on order (7 units)

The main categories of products manufactured are as follows

- Auto Components
- Pulleys
- Shafts
- Nuts
- Machine parts
- Die Set
- Barrel Screw
- Paper cutter
- Non-stick casting
- Tool room
- Die Manufacturing
- LPG Regulator
- Overhead crane
- Pins
- Special tools
- Bushes
- Brake shoe
- Fan parts
- Punches

## 5.4 ELECTROPLATING AND POWDER COATING / HEAT TREATMENT

Electroplating and powder coating industries in Faridabad services the industrial application like – nuts, bolts, sheet metal i.e. mainly the auto parts segment. Out of 59 units covered during the primary survey and 2 units covered during WTA, none of them have expressed any exports, as this industrial segment serves as the local job work centre. This is the only industrial segment which has a dedicated geographical sector with an Association.

## MAJOR EQUIPMENT

Table 26 Main Process Equipment in Electroplating Units

Name of Machine	Application	Energy Used
<b>Hot Water Generator</b>	Develops hot water for the pre-treatment sections	Electricity, Diesel
<b>Water Tank System</b>	Pre-treatment of articles to be electroplated/powder coated	Electricity
<b>Oven</b>	Drying of articles to be electroplated/powder coated before electroplating	Electricity

## PROCESS FLOW DIAGRAM

The following figure has shown typical industry Process Flow Diagram (PFD):

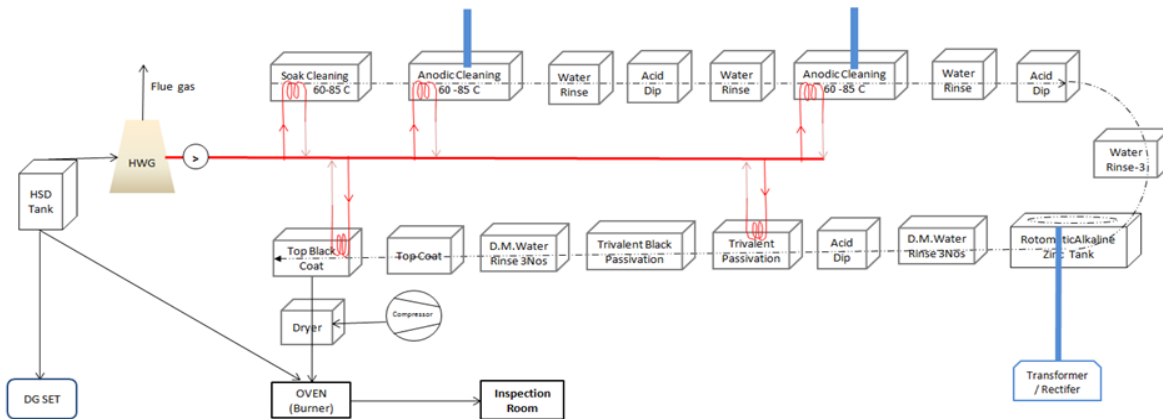

Figure 15 PFD of a typical electroplating unit

The brief description of the above mentioned Process is as follows:

- It is a plating process in which metal ions in a solution are moved by an electric field to coat an electrode
- The anode and cathode in the electroplating cell are both connected to an external supply of direct current — a battery or, more commonly, a rectifier
- The metal at the anode is oxidized from the zero valence state to form cations with a positive charge. These cations associate with the anions in the solution.

Powder coating process

- It is a type of coating that is applied as a free-flowing, dry powder
- The coating is typically applied electro-statically and is then cured under heat to allow it to flow and form a "skin". The powder may be a thermoplastic or a thermo set polymer

## PRODUCTION CAPACITIES

The manufacturing units are engaged in production of different products. The methodology for reporting production varies from unit to unit, i.e.

- based on number of pieces of product manufactured
- Job work (8 units)
- Production in tons, as per details given below
  - < 100 Tons : 2 Units
  - 100-500 Tons : 25 Units
  - 500-1000 Tons : 2 units
  - >1000 Tons : 4 Units

## 5.5 FABRICATION

Fabrication industries in Faridabad service the automobile and the construction industries. Out of 19 units covered during the primary survey, 5 of them have expressed 3-10% of turnover from exports, as this industrial segment serves as the Indian market majorly.

### MAJOR EQUIPMENT

Table 27 Main Equipment in Fabrication Units

Name of Machine	Application	Energy Used
<b>Shearing Machine</b>	To cut metal sheets to desired sizes	Electricity
<b>Lathe Machines/CNC Machines</b>	Drilling holes and achieve desired shape from cut sheets	Electricity
<b>Welding Machines</b>	Welding the parts to make the desired structure	Electricity
<b>Grinding Machines</b>	Grinding the fabricated parts for proper finish	Electricity

### PROCESS FLOW DIAGRAM

The following figure has shown typical industry Process Flow Diagram (PFD):

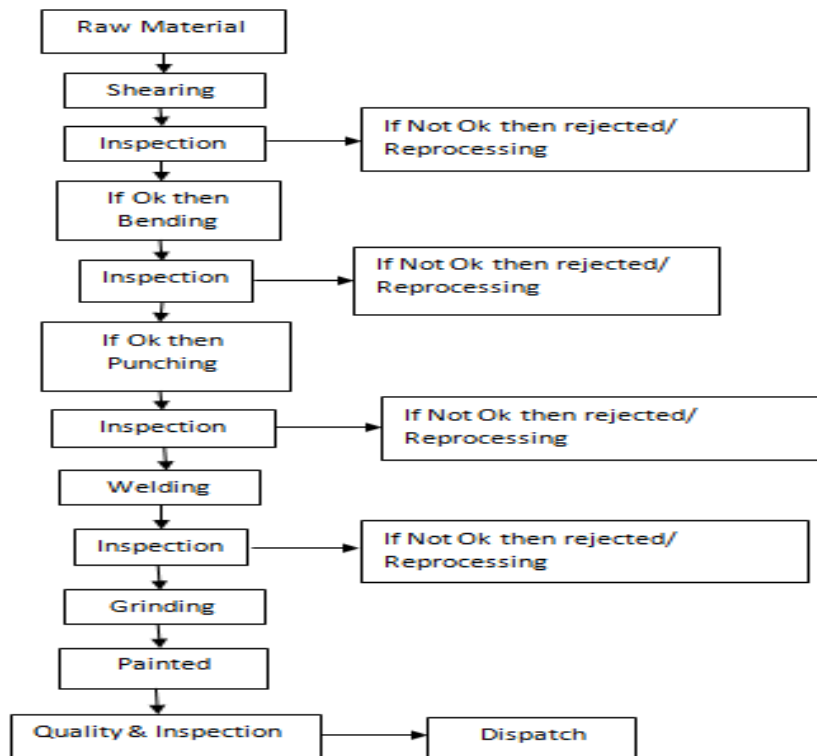

Figure 16 PFD of a fabrication unit



In the unit, sheet metal is the raw material. Sheets are cut into desired shape with the help of shearing machine as per the desired sizes. After that bending process is done on the sheets followed by punching and welding. Necessary grinding is done to remove the excess material and to give smooth finish to the product. After inspection the material is sent for painting job. After paint, final inspection is done and products are sent to dispatch.

## PRODUCTION CAPACITIES

The manufacturing units are engaged in production of different products. The methodology for reporting production varies for all the units surveyed is based on number of pieces of product manufactured. The products manufactured are as follows

- Cranes
- Printing Machines
- Packaging Machines
- Fan brackets
- Exhaust System
- Material handling machine
- Cable & Hose Machine
- Pump
- Valve
- Heat Exchanger
- Hydraulic System
- Corrugated Boxes
- Steel Almirahs
- Combine Parts
- Special Machines
- Tool Room
- Construction Machines
- Fan parts
- Punches

## 5.6 RAILWAY PRODUCTS/INDUSTRIAL FASTENERS

Railway Products & Industrial industries in Faridabad cluster manufacture and assemble the products like –Crane hoist, EOT crane, gear box assembly etc. They cater to the needs of the automobile sector, manufacturing sector and heavy machine industries. Some of the industries are exported their product.

## MAJOR EQUIPMENT

The following table summarizes the major equipments in this segment of the industry:

Table 28 Main Equipment for Railway Products/ Industrial Fasteners

Name of Machine	Application	Energy Used
<b>Shearing Machine</b>	To cut metal sheets to desired sizes	Electricity
<b>Lathe Machines/CNC Machines</b>	Drilling holes and achieve desired shape from cut sheets	Electricity
<b>Welding Machines</b>	Welding the parts to make the desired structure	Electricity
<b>Grinding Machines</b>	Grinding the fabricated parts for proper finish	Electricity

## PROCESS FLOW DIAGRAM

The following figure has shown typical industry Process Flow Diagram (PFD)

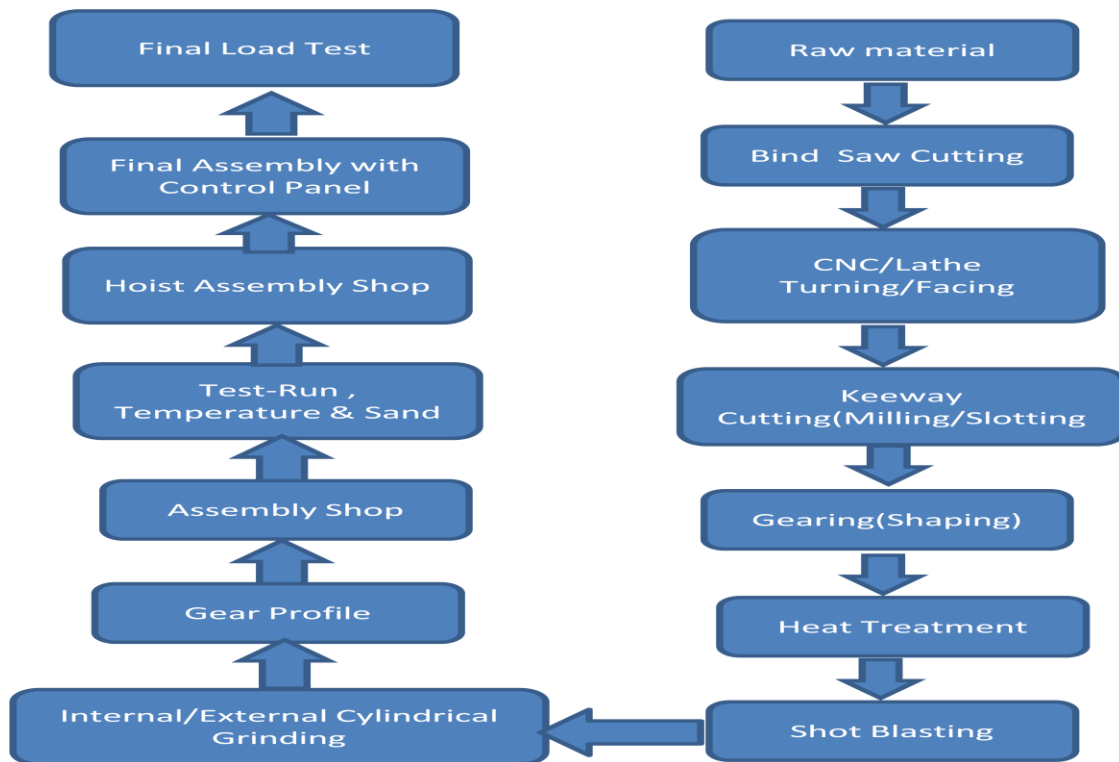

Figure 17 PFD of a typical Machine Manufacturing unit

There final product is hoist assembly included with shaft, drum, rope and electrical components. The brief description of the above mentioned Process will be,

- The machine and manufacturing industry process will be combination of Sheet-metal, Foundry, and Machining industry process.
- The product will assembled of internal parts, after complete assembling the product will be test for different load condition.

## PRODUCTION CAPACITIES

The manufacturing units are engaged in production of different products. The methodology for reporting production varies for all the units surveyed is based on number of pieces of product manufactured and inventorization based on production capacity is not possible.

### 5.7 FORGING

Forging industries in Faridabad manufacture a variety of products like–dies, valve body, die casted rotors and aluminium components, hot forged and CNC/VMC Turned components, Tractor Parts. Out of the 31 units surveyed and another 5 units where WTA was conducted, only 4 of them have been exporting their products.

## MAJOR EQUIPMENT

Table 29 Main Plant and Equipment in Forging Plant

Name of Machine	Application	Energy Used
<b>Shearing Machine</b>	To cut rods to desired shape	Electricity
<b>Forging Furnace</b>	Heating the cut rods to desired temperature to soften the material	Furnace Oil, Diesel, Electricity
<b>Forging Hammer</b>	Hammering the soft hot rods to desired shapes	Electricity, steam from Boiler run by Diesel/electricity
<b>Treatment Furnace</b>	Re-heating the material for heat treatment	Furnace Oil, Diesel, Electricity
<b>Shot Blasting</b>	Providing finish to the forged material	Electricity
<b>Grinding</b>	Providing finish to the forged material	Electricity
<b>Lathe Machines/ CNC Machines</b>	Drilling holes and achieve desired shape from cut sheets	Electricity

## PROCESS FLOW DIAGRAM

The following figure has shown typical industry Process Flow Diagram (PFD):

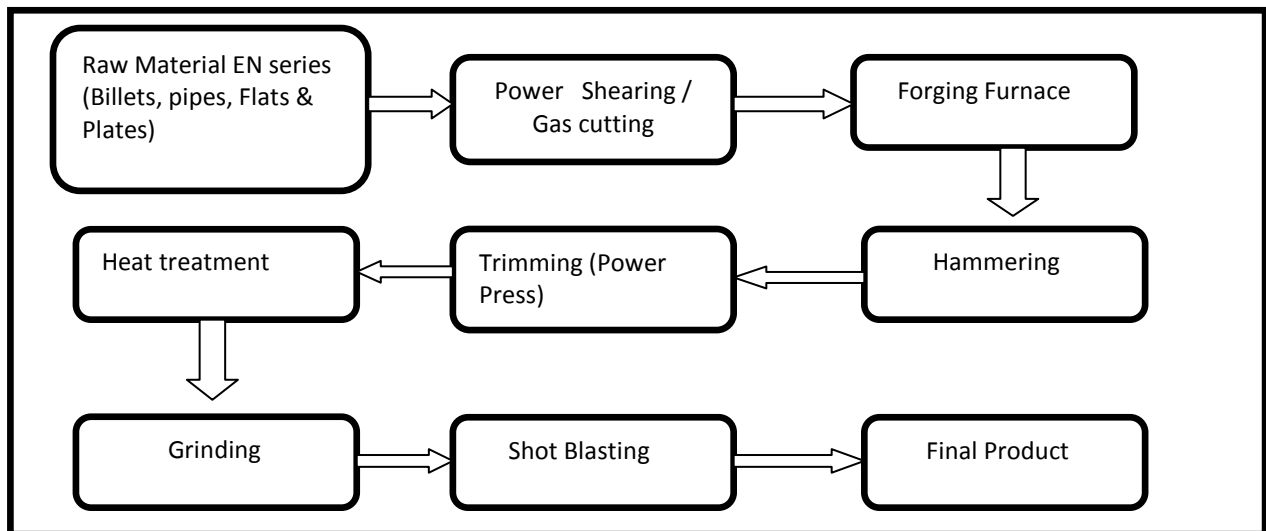

Figure 18 PFD of a forging unit

The brief description of the above mentioned Process will be,

1. The raw material will subjected to initial cutting/ shearing by gas cutting machine/ Power shearing machine.
2. The required and preliminary sized product then undergone to furnace. In furnace it will be heated up to semi-molten shape.
3. This semi-molten material will be subjected under power press to get a exact shape by die
4. After pressing the product will subjected to heat treatment process to improve mechanical properties. Grinding and shot blasting process is also done on the Final Product.

## PRODUCTION CAPACITIES

The manufacturing units are engaged in production of different products. The methodology for reporting production varies for all the units surveyed is based on number of pieces of product manufactured or on the basis of tons of product produced. For the latter, the disaggregation by capacity is as follows:

- < 500 tons production in 2011-12 : 5 Units
- 500- 1000 tons production : 1 unit
- > 1000 tons production : 2 units

## 5.8 FOUNDRY / CASTING

Foundry industries in Faridabad sector manufacturing the Products like – Steel Castings, Rolled Products, Machine Parts, and Pumps Casting etc. They supply their products to leading automobile manufacturing companies and heavy machine industries. Out of the 29 industries covered under the survey and 2 units covered under WTA, none of them are into exports.

## MAJOR EQUIPMENT

Table 30 Main Plant and Equipment in a Foundry

Name of Machine	Application	Energy Used
<b>Sand Mixing</b>	Preparation of sand for sand moulding	Electricity
<b>Cupola</b>	Melting the scrap and other ingredients	Coke
<b>Grinding</b>	Providing finish to the material	Electricity
<b>Lathe Machines/ CNC Machines</b>	Drilling holes and achieve desired shape from cut sheets	Electricity

## PROCESS FLOW DIAGRAM

The following figure has shown typical industry Process Flow Diagram (PFD):

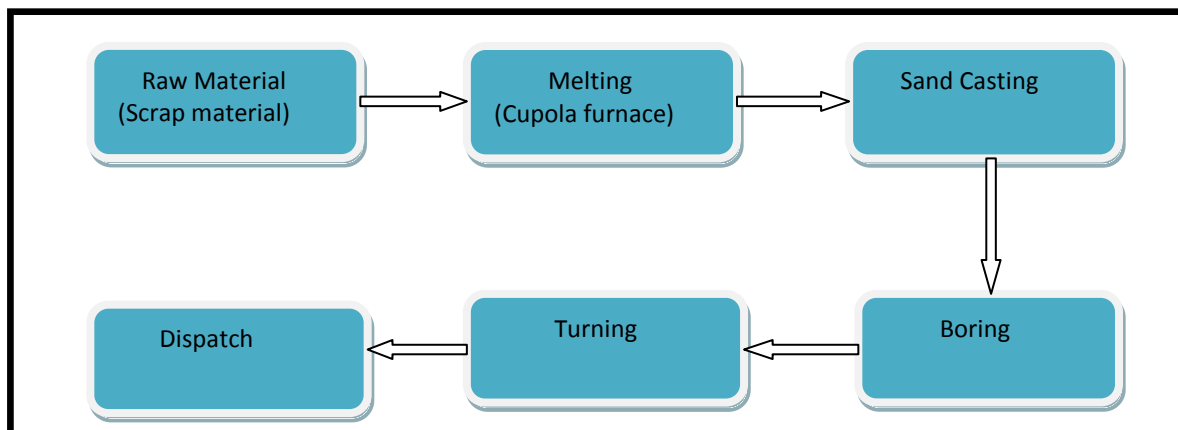

Figure 19 PFD of a foundry

The brief description of the above mentioned Process will be,

1. The raw material (scrap material) is heating upto the melting temperature in furnace.
2. Then the molten metal will be poured it to the die and it gradually cooled.
3. After cooling the product will subjected to small lathe works like boring, turning to obtain final dimension.

## PRODUCTION CAPACITIES

The manufacturing units are engaged in production of different products. The classification of units based on capacity is as follows:

Table 31 Production Capacity in Foundries Surveyed

Production in 2011-12	Number of Units
<100 Tons per year	9
100-500 Tons per year	10
500-1000 Tons per year	5
1000-5000 tons per year	2
More than 5000 tons per year	1
Job Work	2

## 5.9 PLASTIC MOULDING / RUBBER MOULDING & PACKAGING

Plastic Moulding, Rubber moulding & packing industry in Faridabad cluster manufacture products like –plastic motor vehicle parts, Plastic moulds and components, automobile parts etc. They supply their products to leading automobile industries and heavy machine industries. Very few of them are into export of their products.

## MAJOR EQUIPMENT

The following table summarises the major equipments present in the industrial segment:

Table 32 Main Plant and Equipment - Moulding & Wire Drawing

Name of Machine	Application	Energy Used
<b>Injection Moulding Machine</b>	Melting the plastic pellets and injecting to pre-designed moulds to make the desired product	Electricity
<b>Manual Finishing</b>	Cutting the risers	-
<b>Quality Testing</b>	Manual Checking	-

## PROCESS FLOW DIAGRAM

The following figure has shown typical industry Process Flow Diagram (PFD)

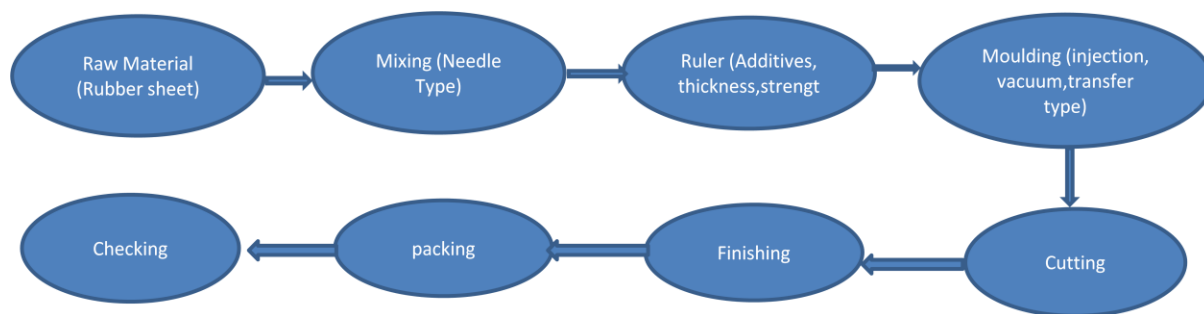

Figure 20 PFD of a typical Plastic Moulding Unit

The brief description of the above mentioned Process will be,

- This is simple process of putting the plastic grains into injection moulding machines and formed according to die. Some have their tool room to make die.
- The punching action has been done by hydraulic press, and the desired size of product will obtained after machining process. After some welding process the final product will come

## PRODUCTION CAPACITIES

The manufacturing units are engaged in production of different products. The methodology for reporting production varies for all the units surveyed is based on number of pieces of product manufactured or by the production in tons. The inventORIZATION of units where information is on basis of tons is as follows:

- < 100 tons/year production : 6 units
- 100-500 tons/year production : 4 units
- > 500 tons/year production : 1 unit

### 5.10 TEXTILE APPAREL & DYEING

Textile apparel & Dyeing industry in Faridabad cluster manufacture products like – Fashion ware, Leather Goods and Accessories such as Bags, Travel Accessories, Gloves, Hats and Caps, Readymade Garments .They are supplied their products to leading textile industries in India and overseas.

## MAJOR EQUIPMENT

Table 33 Main Plant and Equipment – Textile & Garment Manufacturing

Name of Machine	Application	Energy Used
<b>Cutting Machine</b>	Cutting the fabric to desired pattern	Electricity
<b>Stitching Machine</b>	Stitching the cut pieces, as per requirement	Electricity
<b>Drilling Machine</b>	Drilling holes are desired location	Electricity
<b>Finishing &amp; Quality Testing</b>	Quality Checking & Manual Repair	-

---

## PROCESS FLOW DIAGRAM

The following figure has shown typical industry Process Flow Diagram (PFD)

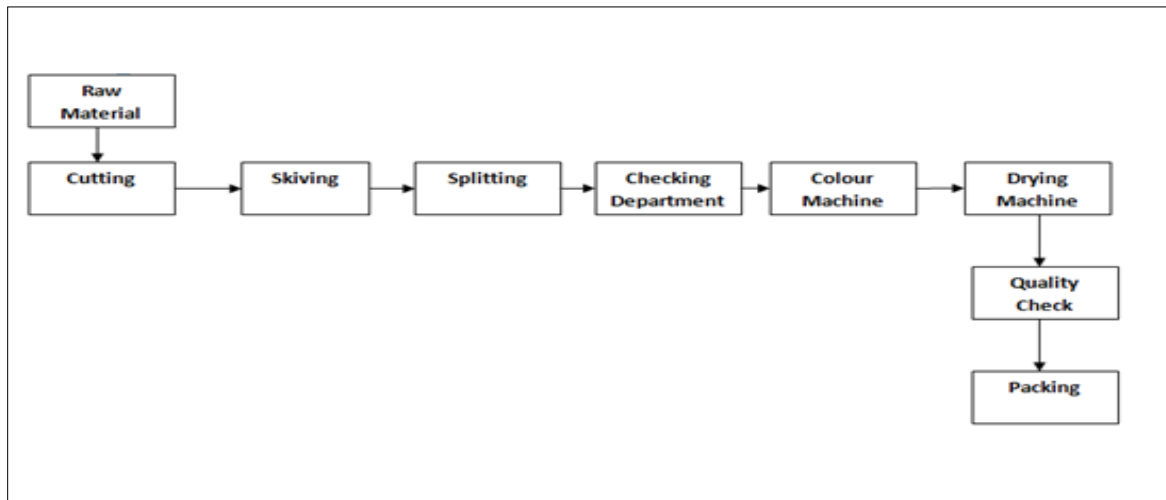

Figure 21 PFD of a leather goods manufacturing unit

The brief description of the above mentioned Process is as follows:

1. The processed leather is procured and stored in a conditioned environment
2. The skiving machine is used to cut the leather materials in slice. The process is used instead of rolling the material to shape when the material must not be work hardened, or must not shed minute slivers of metal later which is common in cold rolling processes
3. For a few products like leather belts, there is a need for edge colouring
4. There is a lot of manual effort involved in stitching, pasting, quality checks and packaging

---

## PRODUCTION CAPACITIES

The manufacturing units are engaged in production of different products. The methodology for reporting production varies for all the units surveyed for units where data is available, the break up is as follows:

- a) Lakh meters of garments manufactured
  - a. < 10 Lakh meters per year : 2 units
  - b. 10 -50 Lakh meters per year : 2 units
  - c. >50 Lakh meters per year : 3 units
- b) production in tons is as follows
  - a. < 100 tons/year : 1 unit
  - b. 100-500 tons /year: 3 units
  - c. >500 tons /year: 1 unit

## 6. ESTIMATED ENERGY CONSUMPTION PATTERN IN CLUSTER & SAVING POTENTIAL

### 6.1 Energy Types, Sources & Usage

The main source of energy usage depends on the sector and the ones encountered in the cluster are as follows:

Table 34 Energy Types, Specification, price & source used in Faridabad Cluster

Fuel Type	Specification	Price/Tariff	Source
Electricity (DHBVN)	As per the desired voltage levels. However, the availability of electricity has been highlighted by every entrepreneur as a major hurdle in Faridabad	LT Industry (less than 11 kV connections & upto 50 kW contract demand) <ul style="list-style-type: none"> <li>&lt; 20 kW: 5.67 Rs/kWh &amp; 150 Rs/kW</li> <li>20 to 50 kW: 5.42 Rs/kWh &amp; 150 Rs/kW</li> </ul> HT Industry (above 50 kW) <ul style="list-style-type: none"> <li>At 11 kV: 4.70 Rs/kVAh, 0.31 Rs/kWh &amp; 130 Rs/kVA</li> <li>At 33 kV: 4.60 Rs/kVAh, 0.31 Rs/kWh &amp; 130 Rs/kVA</li> <li>At 66 or 132 kV: 4.50 Rs/kVAh, 0.31 Rs/kWh &amp; 130 Rs/kVA</li> </ul>	DHBVN
Electricity (Open Access)	As per the desired voltage levels. One of the solutions for entrepreneurs suffering from poor electricity availability and with contract demand greater than 1 MW.	Price varies with demand of electricity. As gathered from discussion with a few users it ranges from Rs 4 to 8 Rs/kWh	Power Traders like Global Energy Ltd, Adani either through bilateral tie-ups or Power Exchange (IEX and PXIL)
Furnace Oil	Being used in several industrial segments with furnaces like forging	Rs 40 per litre <sup>11</sup>	Local Dealers for all the Oil PSUs
Diesel	Being used by all the units, as power supply from DHBVN is erratic	Rs 47 per litre <sup>12</sup>	Local Dealers for all the Oil PSUs
Coke	Mainly used by the cupola based foundry units. They want foundry coke or metallurgical coke, which has less than 12% ash content & Fixed Carbon 86 to 90% <sup>13</sup>	Rs 27 to 20 per kg <sup>13</sup>	Single Point sourcing done with traders in Kolkata by the Foundry Association. E.g. Ennore Coke Ltd, Kolkata. Some units procure imported coke from Gujarat.
Piped Natural	9000 kCal/SCM or 12,857 kCal/kg (at 1.5 bar pressure)	Current price is 37.41 Rs/SCM with proforma and 40.61 Rs/SCM without	Adani Gas, the local City Gas Distribution

<sup>11</sup> Average of 28 units surveyed by Nielsen

<sup>12</sup> Discussion with an Aluminium Casting unit

<sup>13</sup> Discussion with Foundry Units & Faridabad Foundry Association



Fuel Type	Specification	Price/Tariff	Source
Gas	with Methane 87 to 96% & Ethane 1.5 to 5.1% <sup>14</sup>	proforma. Price variation, which may happen once in a fortnight, is driven by local factors like price of Furnace Oil (as FO is the nearest competitor to be substituted for furnace heating application in industries) as well as global factors like price of crude oil. The price of gas (excl tax) has increased by 37.55% over the last 1.5 yrs. <sup>14</sup>	(CGD) licensee in Faridabad
Biomass, primarily wood	Being used in some Rubber Moulding units & chemical units	Rs 4.65 per kg <sup>15</sup>	Local suppliers

## 6.2 Energy Consumption pattern and Energy Saving Potential

The following stack graphs shows the energy mix based on annual cost of energy for each sector. There are several types of energy sources used within a particular industry segment. The percentage figure mentioned in the name of the industrial segment indicates the percentage of occurrence from among the surveyed units.

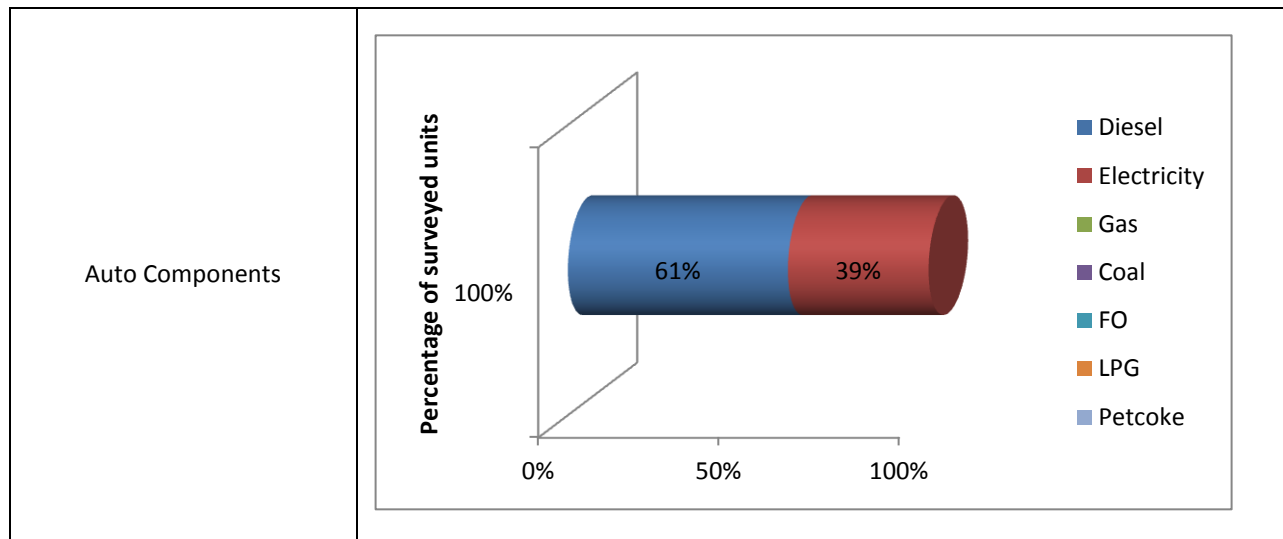

<sup>14</sup> Discussion with Adani Gas

<sup>15</sup> Average of data collected for 6 units in Nielsen Survey

Casting

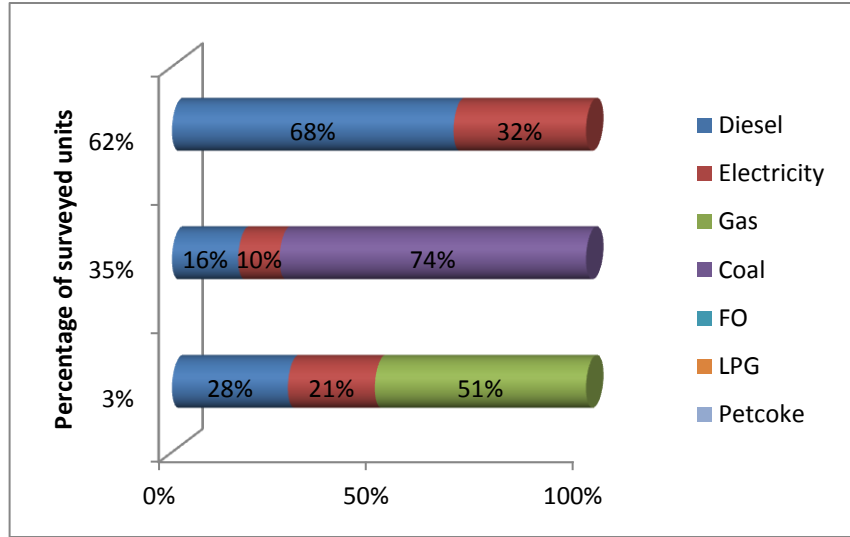

Die Casting

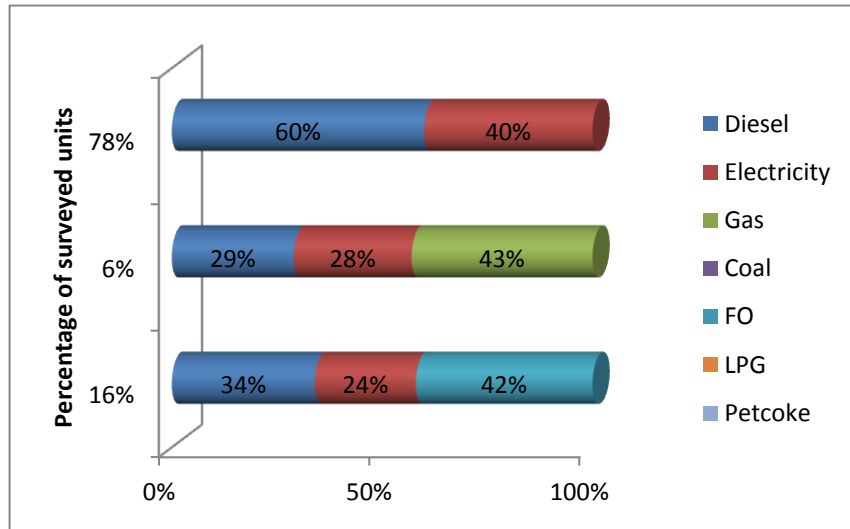

<p style="text-align: center;">Foundry</p>	<p>Percentage of surveyed units</p> <table border="1"> <thead> <tr> <th>Category</th> <th>Diesel</th> <th>Electricity</th> <th>Gas</th> <th>Coal</th> <th>FO</th> <th>LPG</th> <th>Petcoke</th> </tr> </thead> <tbody> <tr> <td>21%</td> <td>58%</td> <td>42%</td> <td>0%</td> <td>0%</td> <td>0%</td> <td>0%</td> <td>0%</td> </tr> <tr> <td>69%</td> <td>17%</td> <td>6%</td> <td>0%</td> <td>78%</td> <td>0%</td> <td>0%</td> <td>0%</td> </tr> <tr> <td>10%</td> <td>70%</td> <td>14%</td> <td>0%</td> <td>0%</td> <td>0%</td> <td>15%</td> <td>0%</td> </tr> </tbody> </table>	Category	Diesel	Electricity	Gas	Coal	FO	LPG	Petcoke	21%	58%	42%	0%	0%	0%	0%	0%	69%	17%	6%	0%	78%	0%	0%	0%	10%	70%	14%	0%	0%	0%	15%	0%								
Category	Diesel	Electricity	Gas	Coal	FO	LPG	Petcoke																																		
21%	58%	42%	0%	0%	0%	0%	0%																																		
69%	17%	6%	0%	78%	0%	0%	0%																																		
10%	70%	14%	0%	0%	0%	15%	0%																																		
<p style="text-align: center;">Forging</p>	<p>Percentage of surveyed units</p> <table border="1"> <thead> <tr> <th>Category</th> <th>Diesel</th> <th>Electricity</th> <th>Gas</th> <th>Coal</th> <th>FO</th> <th>LPG</th> <th>Petcoke</th> </tr> </thead> <tbody> <tr> <td>13%</td> <td>49%</td> <td>22%</td> <td>0%</td> <td>0%</td> <td>0%</td> <td>25%</td> <td>0%</td> </tr> <tr> <td>40%</td> <td>54%</td> <td>41%</td> <td>0%</td> <td>0%</td> <td>0%</td> <td>0%</td> <td>0%</td> </tr> <tr> <td>47%</td> <td>29%</td> <td>24%</td> <td>0%</td> <td>0%</td> <td>47%</td> <td>0%</td> <td>0%</td> </tr> </tbody> </table>	Category	Diesel	Electricity	Gas	Coal	FO	LPG	Petcoke	13%	49%	22%	0%	0%	0%	25%	0%	40%	54%	41%	0%	0%	0%	0%	0%	47%	29%	24%	0%	0%	47%	0%	0%								
Category	Diesel	Electricity	Gas	Coal	FO	LPG	Petcoke																																		
13%	49%	22%	0%	0%	0%	25%	0%																																		
40%	54%	41%	0%	0%	0%	0%	0%																																		
47%	29%	24%	0%	0%	47%	0%	0%																																		
<p style="text-align: center;">Heat Treatment</p>	<p>Percentage of surveyed units</p> <table border="1"> <thead> <tr> <th>Category</th> <th>Diesel</th> <th>Electricity</th> <th>Gas</th> <th>Coal</th> <th>FO</th> <th>LPG</th> <th>Petcoke</th> </tr> </thead> <tbody> <tr> <td>45%</td> <td>61%</td> <td>36%</td> <td>0%</td> <td>0%</td> <td>0%</td> <td>0%</td> <td>0%</td> </tr> <tr> <td>5%</td> <td>42%</td> <td>15%</td> <td>43%</td> <td>0%</td> <td>0%</td> <td>0%</td> <td>0%</td> </tr> <tr> <td>15%</td> <td>29%</td> <td>16%</td> <td>0%</td> <td>0%</td> <td>0%</td> <td>55%</td> <td>0%</td> </tr> <tr> <td>35%</td> <td>25%</td> <td>25%</td> <td>0%</td> <td>0%</td> <td>50%</td> <td>0%</td> <td>0%</td> </tr> </tbody> </table>	Category	Diesel	Electricity	Gas	Coal	FO	LPG	Petcoke	45%	61%	36%	0%	0%	0%	0%	0%	5%	42%	15%	43%	0%	0%	0%	0%	15%	29%	16%	0%	0%	0%	55%	0%	35%	25%	25%	0%	0%	50%	0%	0%
Category	Diesel	Electricity	Gas	Coal	FO	LPG	Petcoke																																		
45%	61%	36%	0%	0%	0%	0%	0%																																		
5%	42%	15%	43%	0%	0%	0%	0%																																		
15%	29%	16%	0%	0%	0%	55%	0%																																		
35%	25%	25%	0%	0%	50%	0%	0%																																		

<p>Industrial Fasteners</p>	<p>A 3D horizontal stacked bar chart showing the percentage of surveyed units for Industrial Fasteners. The bar is divided into two segments: Diesel (blue, 88%) and Electricity (red, 12%). The x-axis is labeled 'Percentage of surveyed units' and ranges from 80% to 100% with major ticks every 5%. A legend on the right lists seven energy sources: Diesel, Electricity, Gas, Coal, FO, LPG, and Petcoke.</p> <table border="1"> <thead> <tr> <th>Energy Source</th> <th>Percentage</th> </tr> </thead> <tbody> <tr> <td>Diesel</td> <td>88%</td> </tr> <tr> <td>Electricity</td> <td>12%</td> </tr> <tr> <td>Gas</td> <td>0%</td> </tr> <tr> <td>Coal</td> <td>0%</td> </tr> <tr> <td>FO</td> <td>0%</td> </tr> <tr> <td>LPG</td> <td>0%</td> </tr> <tr> <td>Petcoke</td> <td>0%</td> </tr> </tbody> </table>	Energy Source	Percentage	Diesel	88%	Electricity	12%	Gas	0%	Coal	0%	FO	0%	LPG	0%	Petcoke	0%
Energy Source	Percentage																
Diesel	88%																
Electricity	12%																
Gas	0%																
Coal	0%																
FO	0%																
LPG	0%																
Petcoke	0%																
<p>Sheet Metal</p>	<p>A 3D horizontal stacked bar chart showing the percentage of surveyed units for Sheet Metal. The bar is divided into two segments: Diesel (blue, 60%) and Electricity (red, 40%). The x-axis is labeled 'Percentage of surveyed units' and ranges from 0% to 100% with major ticks at 0%, 50%, and 100%. A legend on the right lists seven energy sources: Diesel, Electricity, Gas, Coal, FO, LPG, and Petcoke.</p> <table border="1"> <thead> <tr> <th>Energy Source</th> <th>Percentage</th> </tr> </thead> <tbody> <tr> <td>Diesel</td> <td>60%</td> </tr> <tr> <td>Electricity</td> <td>40%</td> </tr> <tr> <td>Gas</td> <td>0%</td> </tr> <tr> <td>Coal</td> <td>0%</td> </tr> <tr> <td>FO</td> <td>0%</td> </tr> <tr> <td>LPG</td> <td>0%</td> </tr> <tr> <td>Petcoke</td> <td>0%</td> </tr> </tbody> </table>	Energy Source	Percentage	Diesel	60%	Electricity	40%	Gas	0%	Coal	0%	FO	0%	LPG	0%	Petcoke	0%
Energy Source	Percentage																
Diesel	60%																
Electricity	40%																
Gas	0%																
Coal	0%																
FO	0%																
LPG	0%																
Petcoke	0%																
<p>Fabrication</p>	<p>A 3D horizontal stacked bar chart showing the percentage of surveyed units for Fabrication. The bar is divided into two segments: Diesel (blue, 54%) and Electricity (red, 46%). The x-axis is labeled 'Percentage of surveyed units' and ranges from 0% to 100% with major ticks at 0%, 50%, and 100%. A legend on the right lists seven energy sources: Diesel, Electricity, Gas, Coal, FO, LPG, and Petcoke.</p> <table border="1"> <thead> <tr> <th>Energy Source</th> <th>Percentage</th> </tr> </thead> <tbody> <tr> <td>Diesel</td> <td>54%</td> </tr> <tr> <td>Electricity</td> <td>46%</td> </tr> <tr> <td>Gas</td> <td>0%</td> </tr> <tr> <td>Coal</td> <td>0%</td> </tr> <tr> <td>FO</td> <td>0%</td> </tr> <tr> <td>LPG</td> <td>0%</td> </tr> <tr> <td>Petcoke</td> <td>0%</td> </tr> </tbody> </table>	Energy Source	Percentage	Diesel	54%	Electricity	46%	Gas	0%	Coal	0%	FO	0%	LPG	0%	Petcoke	0%
Energy Source	Percentage																
Diesel	54%																
Electricity	46%																
Gas	0%																
Coal	0%																
FO	0%																
LPG	0%																
Petcoke	0%																

<p>Chemical/Paints</p>	<p>Percentage of surveyed units</p> <table border="1"> <thead> <tr> <th>Energy Source</th> <th>Percentage</th> </tr> </thead> <tbody> <tr> <td>Diesel</td> <td>55%</td> </tr> <tr> <td>Electricity</td> <td>46%</td> </tr> <tr> <td>Gas</td> <td>18%</td> </tr> <tr> <td>Coal</td> <td>0%</td> </tr> <tr> <td>FO</td> <td>0%</td> </tr> <tr> <td>LPG</td> <td>0%</td> </tr> <tr> <td>Petcoke</td> <td>0%</td> </tr> </tbody> </table>	Energy Source	Percentage	Diesel	55%	Electricity	46%	Gas	18%	Coal	0%	FO	0%	LPG	0%	Petcoke	0%
Energy Source	Percentage																
Diesel	55%																
Electricity	46%																
Gas	18%																
Coal	0%																
FO	0%																
LPG	0%																
Petcoke	0%																
<p>Electroplating</p>	<p>Percentage of surveyed units</p> <table border="1"> <thead> <tr> <th>Energy Source</th> <th>Percentage</th> </tr> </thead> <tbody> <tr> <td>Diesel</td> <td>66%</td> </tr> <tr> <td>Electricity</td> <td>43%</td> </tr> <tr> <td>Gas</td> <td>0%</td> </tr> <tr> <td>Coal</td> <td>0%</td> </tr> <tr> <td>FO</td> <td>0%</td> </tr> <tr> <td>LPG</td> <td>0%</td> </tr> <tr> <td>Petcoke</td> <td>0%</td> </tr> </tbody> </table>	Energy Source	Percentage	Diesel	66%	Electricity	43%	Gas	0%	Coal	0%	FO	0%	LPG	0%	Petcoke	0%
Energy Source	Percentage																
Diesel	66%																
Electricity	43%																
Gas	0%																
Coal	0%																
FO	0%																
LPG	0%																
Petcoke	0%																
<p>Plastic</p>	<p>Percentage of surveyed units</p> <table border="1"> <thead> <tr> <th>Energy Source</th> <th>Percentage</th> </tr> </thead> <tbody> <tr> <td>Diesel</td> <td>50%</td> </tr> <tr> <td>Electricity</td> <td>50%</td> </tr> <tr> <td>Gas</td> <td>0%</td> </tr> <tr> <td>Coal</td> <td>0%</td> </tr> <tr> <td>FO</td> <td>0%</td> </tr> <tr> <td>LPG</td> <td>0%</td> </tr> <tr> <td>Petcoke</td> <td>0%</td> </tr> </tbody> </table>	Energy Source	Percentage	Diesel	50%	Electricity	50%	Gas	0%	Coal	0%	FO	0%	LPG	0%	Petcoke	0%
Energy Source	Percentage																
Diesel	50%																
Electricity	50%																
Gas	0%																
Coal	0%																
FO	0%																
LPG	0%																
Petcoke	0%																

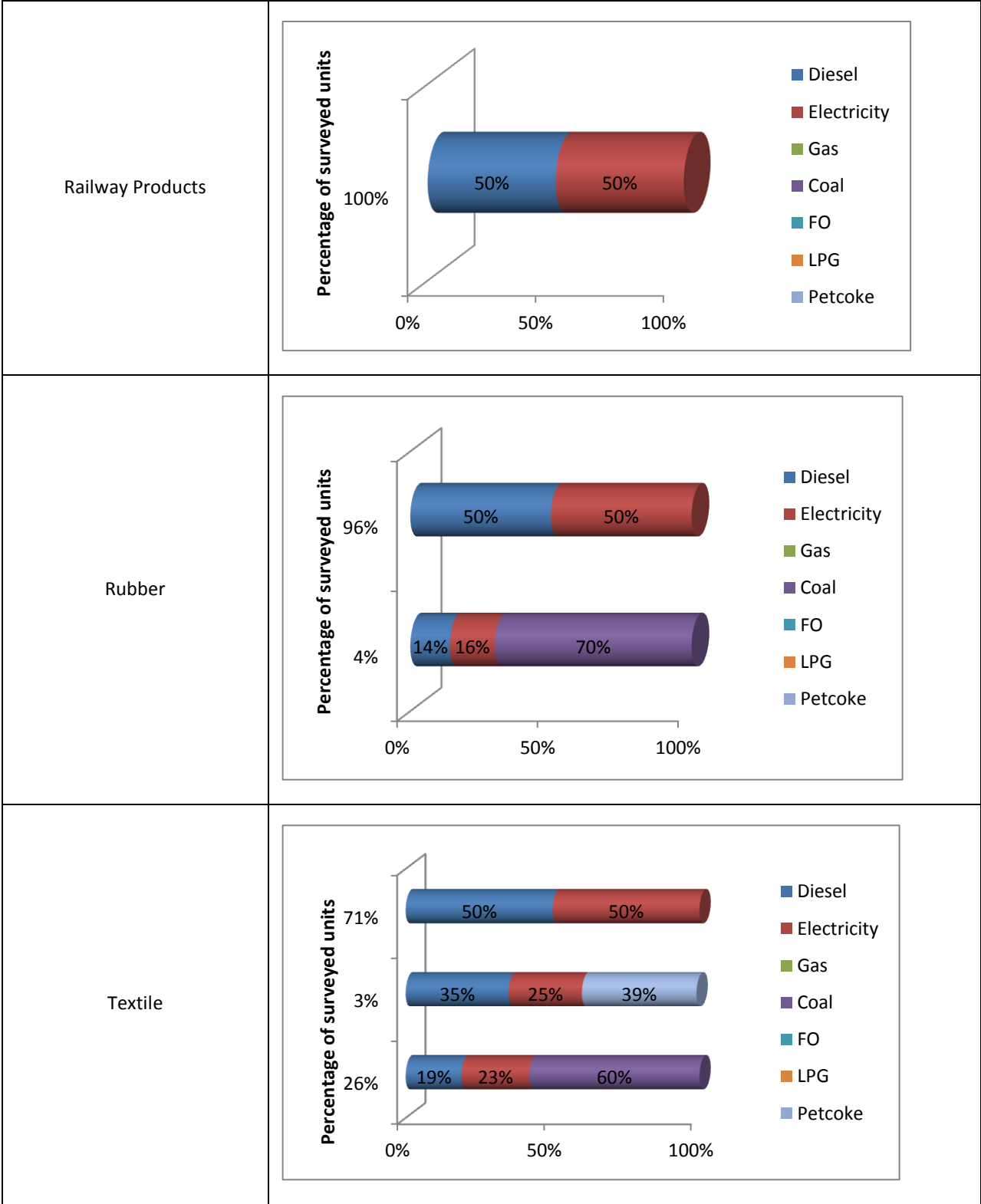

Figure 22 Sectoral Energy Mix: Cost Based

From the survey information to enable classification based on connected load was not available, however based on information available from DHBVN<sup>16</sup>, the classification of industrial connections in Faridabad is as follows:

Table 35 Industry Sector Electricity Connections: DHBVN, Faridabad

Description	Number
Total Number of Connections as on Oct-12	550,236
- Of which, LT Industrial	20,565
- Of Which, HT Industrial, Furnace	19
- Of Which, HT Industrial, Special Agreement	1934

## ENERGY SAVING POTENTIAL

In general the energy saving potential in various sectors is as follows:

Table 36 Energy Saving Potential in Various Sectors

Sector	Energy Characteristics	Areas for Intervention
<b>Forging</b>	Typical Energy Cost : 50% of total manufacturing cost (excluding raw material) Specific Energy Consumption : 6-10 MJ/kg production Cost Reduction Potential : 20%	Automated or manual system to open and close material inlet and outlet doors Waste heat recovery Fuel Switch TIC to avoid overheating Instrumentation and control
<b>Foundry</b>	Typical Energy Cost : 50% of total manufacturing cost (excluding raw material) Specific Energy Consumption : Coke Feed Ratio – 25% (average) Cost Reduction Potential : 10-30%	Energy efficient melting furnace/ cupola Install equipment for main operations such as coal sizer, limestone sizer, and temperature controllers Energy efficient equipment in allied operations like sand preparation and hot metal casting.
<b>Die Casting</b>	Typical Energy Cost : 35% of total manufacturing cost excluding raw material cost Specific Energy Consumption : 24 MJ/kg of finished metal Cost Reduction Potential : 10-20%	Energy conservation in melting furnace operation Fuel Switch Waste heat recovery potential Monitoring temperature of molten metal to avoid over heating Turbo fans and day lighting to improve comfort of workers
<b>Textile Dyeing</b>	Typical Energy Cost : 10% of total manufacturing cost (including raw material) Specific Energy Consumption : Varies depending upon quality Cost Reduction Potential : 15-30%	Boiler performance Steam usage & Condensate recovery Utility equipments, air compressor, Thermic fluid heaters, water pumping etc
<b>Moulding</b>	Typical Energy Cost 12-50% Specific Energy Consumption : NA (Production reported in pieces) Cost Reduction Potential : 15%	Retrofitting VFD in existing machines Air pressure control in blow moulding
<b>Sheet</b>	Typical Energy Cost : 12-28%	Servo control for motors on stamping/pressing

<sup>16</sup> Source : <http://www.dhbvn.com/main/information/statisticaldata/1.pdf>

Sector	Energy Characteristics	Areas for Intervention
<b>Metal</b>	Specific Energy Consumption : NA (Production reported in pieces) Cost Reduction Potential : 5-10%	machines to reduce motor loading during idle time of the respective operation Rewound motors should be replaced by energy efficient motors. The payback is generally less than a year. Motor selection is important DG Operations and selection
<b>Machining</b>	Typical Energy Cost : < 10% Specific Energy Consumption : NA (Production reported in pieces) Cost Reduction Potential : 5-10%	Compressor operation optimization & performance improvement Motors of CNC Machines optimally loaded for highest level of efficiency

The areas of intervention described above have been implemented as technology up gradation in some of the industries.

Out of the 400 units 206 units have expressed interest in follow on energy audit during the survey. The criteria for approaching these units for further work would be based on

- a) Annual energy cost
- b) Size of the industry, with priority for medium and small scale industries

---

#### ENERGY INTENSITY IN THE CLUSTER

Based on the survey data of 400 industries, the energy usage intensity amongst the MSME Industries on energy cost basis is 4.62%. Sector wise disaggregation is provided in Table 38.



## 7. MAJOR CHALLENGES AND SUGGESTIONS FOR IMPROVEMENT IN THE CLUSTER

### 7.1 CHALLENGES

The points under each heading are a compilation of the results of the primary survey, observations made during Walk Through Audit (WTA) and a few interactions with entrepreneurs.

#### TECHNOLOGY RELATED

Table 37 Technology related challenges faced by MSME units in Faridabad

S No	Industrial Segments	Technology Related
1	Auto Components / Auto Ancillary	<ul style="list-style-type: none"> <li>These units are a mix of sheet metal, heat treatment, electroplating/powder coating, metal finishing and all the technology required are available locally. The most critical among them being the sheet metal part, which has a few local reputed manufacturers. However, several units were found to be using second hand machines imported from European countries. High end technologies are possible in this segment, considered to be a costly proposal having a big impact on the cost of production per piece and thus making them not competitive in the market</li> <li>13 of the 15 units surveyed during the primary survey were found to have invested in Plant &amp; Machinery in the past 5 years</li> </ul>
2	Casting	<ul style="list-style-type: none"> <li>Technologies used in casting units are not very advanced and have minimal automation. The existing technology is good enough for the available skill set of the manpower and cost conscious customer. However, from the point of view of energy efficiency, the specific energy consumption is clearly very high</li> <li>32 of the 35 units surveyed during the primary survey were found to have invested in Plant &amp; Machinery in the past 5 years</li> </ul>
3	Chemical / Paint	<ul style="list-style-type: none"> <li>The process for paint making involves mixing of resins and colours with a base; whereas the soaps manufacturing involves mixing of oils with a certain base material to make the detergent cake</li> <li>Technology is not a matter of concern, unless for specialised chemicals</li> <li>26 of the 29 units surveyed during the primary survey were found to have invested in Plant &amp; Machinery in the past 5 years</li> </ul>
4	Die Casting	<ul style="list-style-type: none"> <li>Replica of OEM technologies are available at affordable prices locally; however the awareness levels vary based on the background of the entrepreneur and there is a compromise on the energy efficiency</li> <li>Often the retrofit ideas for performance improvement is to be invented by the entrepreneur</li> <li>21 of the 33 units surveyed during the primary survey were found to have invested in Plant &amp; Machinery in the past 5 years</li> </ul>
5	Electroplating / Powder Coating	<ul style="list-style-type: none"> <li>Technologies are available locally and at affordable prices. There are local technology providers even for turnkey installation</li> <li>From the point of view of energy efficiency, there are options for waste heat recovery and solar energy usage technologies which are not being considered due to cost consideration</li> <li>32 of the 36 units surveyed during the primary survey were found to</li> </ul>

S No	Industrial Segments	Technology Related
		have invested in Plant & Machinery in the past 5 years
6	Fabrication	<ul style="list-style-type: none"> <li>• Fabrication industry involves standard &amp; established technologies in the press shop, welding shop and machining sections. However, high end mechanised technologies like robotics for welding is not possible, as the product is of high variety demanding different processes &amp; low possibility of economies of scale</li> <li>• 30 of the 33 units surveyed during the primary survey were found to have invested in Plant &amp; Machinery in the past 5 years</li> </ul>
7	Forging	<ul style="list-style-type: none"> <li>• Replica of OEM technologies are available at affordable prices locally; however the awareness levels vary based on the background of the entrepreneur</li> <li>• There are local technology providers for furnace and hammer</li> <li>• Lack of confidence on the technology providers of retrofit for apparent EE options like fuel switch for FO burners in furnace to be replaced by PNG burners</li> <li>• 30 of the 31 units surveyed during the primary survey were found to have invested in Plant &amp; Machinery in the past 5 years</li> </ul>
8	Heat Treatment	<ul style="list-style-type: none"> <li>• Technologies are available locally and at affordable prices.</li> <li>• 21 of the 23 units surveyed during the primary survey were found to have invested in Plant &amp; Machinery in the past 5 years</li> </ul>
9	Industrial Fasteners	<ul style="list-style-type: none"> <li>• Technologies are available locally and are affordable for the low end market, which do not need high precision and thus can be managed with low cost machines. For precision components, CNC machines are required, which are expensive</li> <li>• 7 of the 12 units surveyed during the primary survey were found to have invested in Plant &amp; Machinery in the past 5 years</li> </ul>
10	Foundry	<ul style="list-style-type: none"> <li>• Technologies are available locally (75% cupola based &amp; 25% induction furnace based).</li> <li>• There are local technology providers for the cupola furnace, induction furnace, blower; however, they are of different levels of proficiencies and often the retrofit ideas for performance improvement is to be invented by the entrepreneur</li> <li>• The MSME has assisted in standardising the design for Cupola furnaces and past projects funded by GIZ has helped in converting the single blast cupola to divided blast cupola, where there is a 33% improvement in the efficiency of the furnace. However, a few entrepreneurs were found to be not satisfied with the design and attribute the shift to divided blast cupola to be more of a change when their existing single blast cupola were to be scrapped. Further, there is ambiguity in the specification of the blower to be procured based on the MSME design, as the local vendors cannot understand the same</li> <li>• 28 of the 29 units surveyed during the primary survey were found to have invested in Plant &amp; Machinery in the past 5 years</li> </ul>
11	Plastic / Plastic Products	<ul style="list-style-type: none"> <li>• Technologies for Injection Moulding Machines from reputed Indian and MNC manufacturers like Godrej, Siemens and L&amp;T are available in India with a proven life of roughly 15 years.</li> <li>• Entrepreneurs have a low awareness about proven EE technologies like Variable Frequency Drives (VFD) and some of the wrongly commissioned installations have left a bad perception about the technology</li> </ul>

S No	Industrial Segments	Technology Related
		<ul style="list-style-type: none"> <li>30 of the 33 units surveyed during the primary survey were found to have invested in Plant &amp; Machinery in the past 5 years</li> </ul>
12	Railway Equipment	<ul style="list-style-type: none"> <li>The process and the technology are similar to a mix of sheet metal and industrial fasteners segment. Hence technology is available locally and nature of challenges faced similar to that of sheet metal industry.</li> <li>All the 9 units surveyed during the primary survey were found to have invested in Plant &amp; Machinery in the past 5 years</li> </ul>
13	Rubber Products	<ul style="list-style-type: none"> <li>The technology is established and is available locally</li> <li>30 of the 35 units surveyed during the primary survey were found to have invested in Plant &amp; Machinery in the past 5 years</li> </ul>
14	Sheet Metal Components	<ul style="list-style-type: none"> <li>The machinery used by most of the units are quite old and second hand machines imported from European countries</li> <li>High end technologies like Tandem Lines Press, Multi cavity press, usage of robotics in the welding section etc add huge cost to the components to keep the units price competitive in the market</li> <li>17 of the 22 units surveyed during the primary survey were found to have invested in Plant &amp; Machinery in the past 5 years</li> </ul>
15	Textile, Apparel & Dyeing	<ul style="list-style-type: none"> <li>The technology is mostly bought from European countries</li> <li>Technological solution to handle the poor quality of electricity is one of the major concerns in the knitting units</li> <li>27 of the 34 units surveyed during the primary survey were found to have invested in Plant &amp; Machinery in the past 5 years</li> </ul>

- The technology gap between industries of same type is vast.
- Cost is a major factor in selection of plant and machinery and there are inherent inefficiencies in procurement of technology

## ENERGY RELATED

- Erratic Power Supply & very high dependence on diesel for standby power as shown in the table below:

Table 38 Dependence on Diesel Generation set for electricity

S No	Industrial Segments	Total Energy Bill as a % of Turn Over (%)	DG Operation (Hrs/yr)	Cost of diesel in DG (Lakh Rs/yr)	Cost of diesel in DG as % of DHBVN bill (Lakh Rs/yr)
1	Auto Components / Auto Ancillary	7.46%	5,625	46.93	524%
2	Casting	7.25%	3,680	10.94	166%
3	Chemical / Paint	3.39%	8,616	13.73	66%
4	Die Casting	7.11%	2,569	7.1	205%
5	Electroplating / Powder Coating	6.40%	2,388	11.03	69%
6	Fabrication	2.04%	2,139	1.38	14%
7	Forging	5.58%	4,953	22.07	271%
8	Heat Treatment	3.07%	2,320	9.76	156%

S No	Industrial Segments	Total Energy Bill as a % of Turn Over (%)	DG Operation (Hrs/yr)	Cost of diesel in DG (Lakh Rs/yr)	Cost of diesel in DG as % of DHBVN bill (Lakh Rs/yr)
9	Industrial Fasteners	3.32%	1,629	4.6	258%
10	Foundry	44.34%	1,675	10.98	131%
11	Plastic / Plastic Products	2.02%	3,372	4.63	229%
12	Railway Equipment	4.22%	1,970	12.53	94%
13	Rubber Products	4.77%	1,415	4.37	132%
14	Sheet Metal Components	4.24%	1,831	16.74	179%
15	Textile, Apparel & Dyeing	3.30%	1,768	47.37	261%

- Absence of efficient settlement mechanism for open access consumers has been observed in a unit which has been frequently purchasing power from power exchanges.
- Frequent revisions of price of PNG as shown in the figure below:

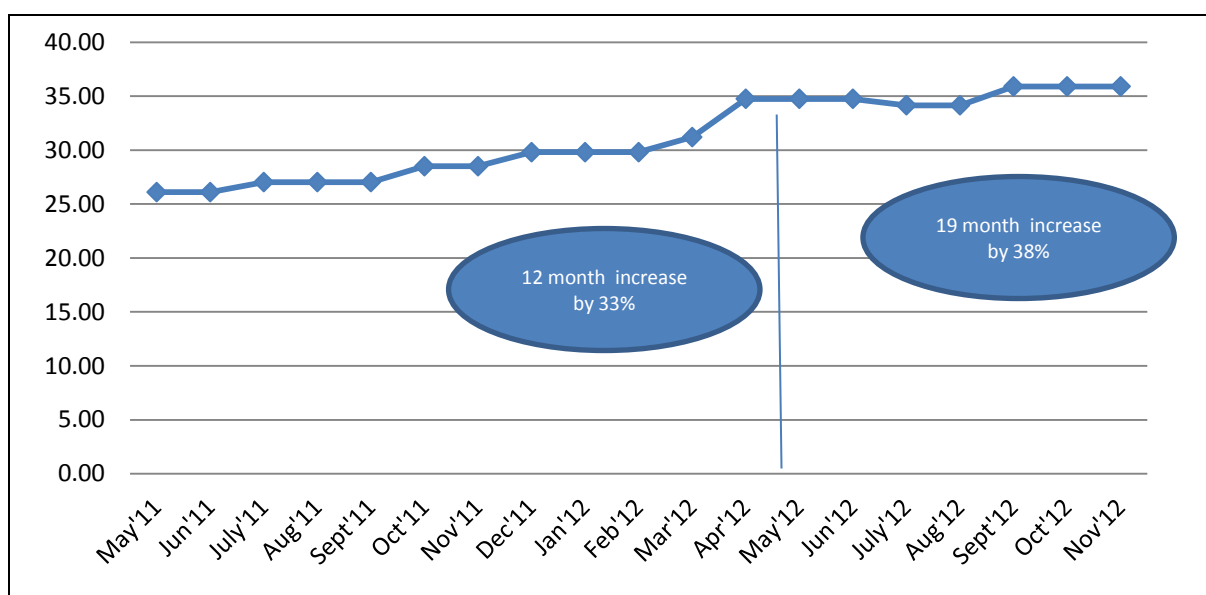

Figure 23 Monthly Variation in the pre-tax price of PNG in Rs/SCM

- Energy data storage and review is done by very few units, mostly medium scale units as the smaller units are busy with handling day-to-day operational issues
- Energy Value addition in the Fabrication, Heat Treatment, Textile, Plastic and Chemical is very low (as can be seen from Table 38), hence not a priority

## MARKETING RELATED

- The SME units in Faridabad generally have tie-ups with OEMs and have a smooth working arrangement. The tie-up with the OEMs is also dependent on the maintenance of product quality measured by the quantification of rejections
- Auto cluster are dependent on large players. For e.g. the recent problem at the Maruti Manesar unit has resulted in loss of production in MSME units in the cluster

- Some of the electroplating units conducting job work were found to be struggling with low capacity utilisation and short time allotted for the batch processing at times

#### RAW MATERIAL AND QUALITY RELATED

- The plastic products/rubber products and textile units have concerns about the fluctuation of price of raw material. In the case of plastic moulding units, some of them import the raw material to avoid

#### PRODUCTS AND THEIR QUALITY RELATED

- The units strive to maintain high quality of product to minimise rejections and continue getting orders from OEMs

#### FINANCE RELATED

- Nearly 70 units have availed of debt financing. 3 units have indicated that they have faced any constraint in availing loans, specifically with respect to the documentation requirements and time taken for loan processing

#### MANPOWER AND SKILLS RELATED

- The following graph shows the employee intensity of different sectors. Almost all the sectors were found to be struggling with the high labour attrition

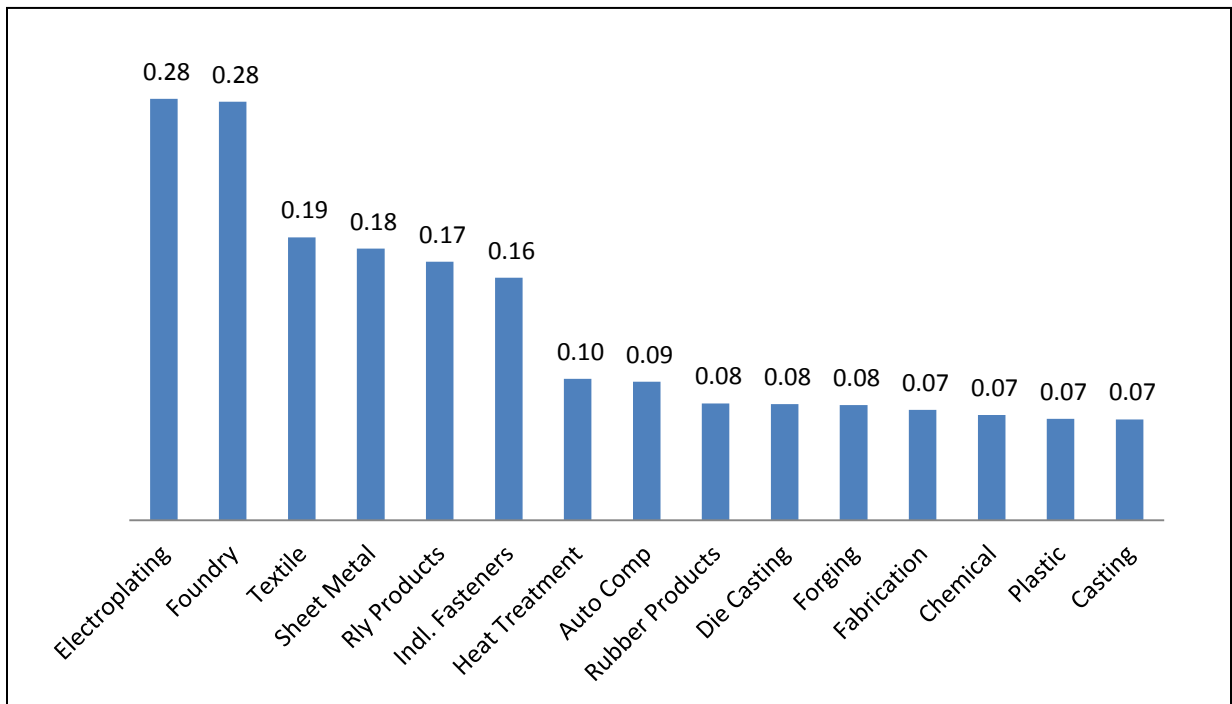

Figure 24 Employee Intensity per industry segment

- Most industries are heavily dependent on one to a few key persons for managerial aspects
- Technical awareness level is relatively low as compared to larger industries sometimes causing a hurdle to shift to latest technologies

## SOCIAL ASPECTS

- The minimum wages of Haryana are the highest and has caused increase in the cost of labour coupled with inflow of labour from other states

Table 39 Minimum wages in Haryana, Punjab & Rajasthan

Category of Labour	Min. Wages in Rajasthan <sup>17</sup>		Min. Wages in Punjab <sup>18</sup>		Min. Wages in Haryana <sup>19</sup>	
	Rate (Rs /Day)	Rate (Rs /month)	Rate (Rs /Day)	Rate (Rs /month)	Rate (Rs /Day)	Rate (Rs /month)
<b>Un-skilled</b>	166	4,316	164.06	4,268	191.04	4,967.29
<b>Semi-skilled</b>	176	4,576	171.18 to 177.34	4,454 to 4,613	196.04 to 201.04	5,097.29 to 5,227.29
<b>Skilled</b>	186	4,836	181.02 to 192.06	4,710 to 4,997	206.04 to 211.04	5,357.29 to 5,487.29
<b>Highly Skilled</b>	236	6,136	201.90 to 209.18	5,253 to 5,443	216.04	5,617.29

Further, in one of the textile unit, the safety of Non-Haryana based labour was informed to be a matter of concern during the night time

- The expectation of social cost of labour (including the expense of hospitalisation) has increased causing either cost implication to the unit owner or higher attrition
- The internal road and infrastructure in the industrial area has been poor causing a dusty environment
- Interventions in the recent past on energy efficiency has left an impression of minimal options for low cost energy cost reduction measures possible

## ENVIRONMENTAL ASPECTS

- Some of the industrial areas like Saroorpur Industrial Area, Krishan Colony etc fall under the non-conformity areas, where there is a relaxation on the compliance on environmental aspects. Several foundry and environmentally polluting units have developed in these areas
- Majority of the plastic moulding units operate from non-conformity areas<sup>20</sup>

## 7.2 SUGGESTIONS FOR IMPROVEMENT IN THE CLUSTER

Table 40 Suggestions for improvement in the Cluster

Solutions for improvement in the cluster
<b>Technology Related</b>
<ul style="list-style-type: none"> <li>• Capacity Building of local vendors to provide good design at affordable costs</li> <li>• Financial support of OEM technology or capacity building of local vendor for low cost option or collective bargaining through the local associations for better deals</li> <li>• Detail design of new ideas identified under the project along with local vendor, as a demonstration for the segment for replication</li> </ul>

<sup>17</sup> <http://rajlabour.nic.in/wageorder-03122012.pdf>

<sup>18</sup> <http://pblabour.gov.in/html/PDF/nov2011/Minimum%20Rates%20Chart1.9.pdf>

<sup>19</sup> <http://hrylabour.gov.in/docs/tenders/labour848419518.pdf>

<sup>20</sup> [http://articles.economictimes.indiatimes.com/2012-06-28/news/32457524\\_1\\_plastic-manufacturers-plastic-industry-smes](http://articles.economictimes.indiatimes.com/2012-06-28/news/32457524_1_plastic-manufacturers-plastic-industry-smes)

Solutions for improvement in the cluster
<ul style="list-style-type: none"> <li>• Technical support for technology evaluation should be made available to all the industrial segments</li> </ul>
<b>Energy Related</b>
<ul style="list-style-type: none"> <li>• Verification of loading of DG set for optimal utilisation of DG &amp; periodic verification of DG performance. Avail open access under single or group customer basis, if possible &amp; seek information in advance about power supply schedule from DHBVN. Technological solutions for common problems like erratic power supply at a cluster level (group of neighbouring industries in a geographical sector)</li> <li>• Focus on improving productivity, energy efficiency, continuous evaluation of alternate fuel sources &amp; other cost reduction measures</li> </ul>
<b>Marketing Related</b>
<ul style="list-style-type: none"> <li>• Diversification of tie-ups with OEMs to overcome prevailing problems with any one particular OEM</li> <li>• Focus on improving productivity</li> </ul>
<b>Raw Material Related</b>
<ul style="list-style-type: none"> <li>• Look for opportunity to Import raw material when at low prices</li> </ul>
<b>Manpower Related</b>
<ul style="list-style-type: none"> <li>• Focus on manpower optimisation through automation, continuous evaluation of permanent manpower Vs contract manpower etc</li> <li>• Develop alternate manpower to handle managerial aspects through proper training</li> <li>• Focus on training of existing staff or hiring semi-skilled manpower when required for more latest technologies</li> <li>• Technology development for low cost energy management and monitoring systems, suitable for the skill set easily available</li> <li>• A few units were found to be felicitated with recognitions for maintaining high quality i.e. lowest rejections by their OEMs. Thus OEM driven cluster programs seem to be having good participation and recognized as a good source of motivation for change</li> </ul>
<b>Social Related</b>
<ul style="list-style-type: none"> <li>• Clearly articulate the extent of cost to be borne by the industry's management &amp; continuously evaluate the same</li> <li>• Follow-up through the local associations to discuss with the state government on the improvement of internal roads and infrastructure</li> <li>• This project has been designed to build confidence of the entrepreneur that the energy efficiency technical consultants would strive to identify low cost measures &amp; also help them implement the same. However, the time horizon of implementation is governed by the situation of resources with the unit and the proficiencies of the local vendors with whom the units generally get modifications done</li> </ul>
<b>Environmental Related</b>
<ul style="list-style-type: none"> <li>• Follow-up through the local associations to discuss with the state government on the converting the non-conformity areas to conformity areas or allot plots in the upcoming IMT Faridabad</li> </ul>

Further suggestions will emerge after substantial field work is completed

## 8. SWOT ANALYSIS

The SWOT analysis shows the internal strength & weakness against the external opportunities and Threats to each of the industrial segments as shown in the

Table 41 Sectoral SWOT Analysis

Elements of SWOT (Strength, Weakness, Opportunities & Threat)	Auto Comp. / Ancillary Casting	Chemical / Paint	Die Casting	Electroplating / Powder Coating	Fabrication	Forging	Heat Treatment	Industrial Fasteners	Foundry	Plastic / Plastic Products	Railway Eqpt	Rubber Products	Sheet Metal Comp.	Textile, Apparel & Dyeing
<b>Strength</b>														
Auto components industry has an established tie-ups with OEMs for orders	√	√	√			√	√		√	√			√	
The penetration of plastic products in the market coupled with the low cost of making die has helped in providing flexibility for higher capacity utilisation										√				
High variations in the cost of raw material										√		√		√
Several industrial units were found to have been established by the members of the same family, mostly in similar sectors, hence getting good overall support						√		√	√	√			√	
<b>Weakness</b>														
Labour intensive units face the problems of rising cost of labour and high attrition	√	√	√	√	√	√	√	√	√	√	√	√	√	√
Die Casting units have high cost of die making thus prohibiting them from moving to other products quickly				√										
Managerial capability is mostly limited to 1-2 persons who shoulder most of business responsibilities	√	√	√	√	√	√	√	√	√	√	√	√	√	√
Human Resources development is not a focus	√	√	√	√	√	√	√	√	√	√	√	√	√	√
Value addition of product is low, thus not demanding high cost												√		



Elements of SWOT (Strength, Weakness, Opportunities & Threat)	Auto Comp. / Ancillary	Casting	Chemical / Paint	Die Casting	Electroplating / Powder Coating	Fabrication	Forging	Heat Treatment	Industrial Fasteners	Foundry	Plastic / Plastic Products	Railway Eqpt	Rubber Products	Sheet Metal Comp.	Textile, Apparel & Dyeing
<b>Opportunity</b>															
Well established cluster known for auto components	√	√		√	√	√	√	√	√	√	√	√		√	
Several associations, to address to the industry's needs	√	√	√	√	√	√	√	√	√	√	√	√	√	√	√
Local Industry segment specific associations available for specific issues					√		√			√	√				
Several OEM's are involved in mentoring and development of MSME units who are their vendors	√			√										√	
Some sectoral consultants were found to be visiting the units (atleast medium scale units or group companies) either at periodic intervals or retained as resident experts for continual improvement							√			√					
New Industrial Township under development beholds high potential for units intending to expand	√	√	√	√	√	√	√	√	√	√	√	√	√	√	√
DIC has commissioned a survey of all industries in Faridabad by Mott Mc Donald. The data from the survey can be a good planning tool for sectoral interventions for energy management	√	√	√	√	√	√	√	√	√	√	√	√	√	√	√
Improved connectivity by the Delhi Metro to increase the availability of skilled manpower from Delhi	√	√	√	√	√	√	√	√	√	√	√	√	√	√	√
The recently inaugurated Kundli-Manesar-Palwal (KMP) expressway is expected to ease the connectivity issues bypassing the congested routes of Delhi	√	√	√	√	√	√	√	√	√	√	√	√	√	√	√
<b>Threat</b>															
High competition to deliver at low cost amongst the several auto units present in Faridabad	√													√	
Auto industry has its inherent monthly variation in demand causing variation in orders for SME units	√	√		√	√	√	√	√	√	√	√			√	

Elements of SWOT (Strength, Weakness, Opportunities & Threat)	Auto Comp. / Ancillary Casting	Chemical / Paint	Die Casting	Electroplating / Powder Coating	Fabrication	Forging	Heat Treatment	Industrial Fasteners	Foundry	Plastic / Plastic Products	Railway Eqpt	Rubber Products	Sheet Metal Comp.	Textile, Apparel & Dyeing
Metal finishing units, being the last item in the complete production chain tend to face tight schedules to deliver the item to the OEM				√										
Rate of increase price of PNG against conventional fuels like Diesel, FO etc has been a concern for existing customers	√	√	√		√	√	√		√					√
Poor infrastructure conditions in Faridabad has forced several entrepreneurs to reside in Delhi leaving lesser time for them to deal with issues	√	√	√	√	√	√	√	√	√	√	√	√	√	√
Erratic power supply, dependence on DG power and rising cost of diesel	√	√	√	√	√	√	√	√	√	√	√	√	√	√
Over dependence on a few OEMs	√	√	√	√	√	√	√	√	√	√	√	√	√	√

## 9. CONCLUSION

Faridabad Industrial cluster is a large cluster; both in terms of geographic spread, number and variety of industries. Faridabad cluster has also established itself as a Light Engineering Manufacturing cluster due to the history of large industrial OEM units like Eicher, Escorts, JCB, Maruti etc. The MSME units have gained experience and are run by the second generation of entrepreneurs in many cases. 10 out of 15 industrial segments are vendors for the automobile OEMs, of which many are supplying to the tractor industry. There is a slight impact of the slowdown in the automobile industry on the MSME units in Faridabad, but this is perceived to be a short term impact, as the future of the automobile industry in India is bright. Moreover, the market for tractors has been steady. There are several local, state-level and national industrial associations, academic and R&D institutions and financial institutions supporting the MSME industries in Faridabad.

The technology used in many of the industrial segments is a replica of the OEM technologies with a compromise on the energy efficiency and productivity. Often the ideas for improvement of productivity and energy efficiency are generated by the entrepreneur, but needs technical assistance for design and capacity building of all stakeholders (vendors, entrepreneur and unit manpower). 11 of the 15 industrial segments (except Railway Products, Electroplating/Metal Finishing, Chemical/Paint and Fabrication) were found to be spending more than 100% of cost of electricity to DHBVN on diesel in DG sets.

There is a good opportunity for energy cost reduction in the more energy intensive units. However the priorities of the units will have to be considered while proposing energy management interventions which do not necessarily have to flow with the schedule of this assignment and hence may pose a problem with implementation of activities as per terms of reference.



e) Value of Investment in Plant and Machinery (excluding investment in land/ land cost)

Value of Investment (excluding investment in land)	Type of Enterprise	Code
Less than Rs.25 Lakh	Micro Enterprise	1
25 Lakh to Rs.5 Crore	Small Enterprise	2
Rs. 5 Crore to Rs.10 Crore	Medium Enterprise	3
More than Rs. 10 Crore	Large Enterprise	4

IF CODED 4, THANK AND TERMINATE THE INTERVIEW, ELSE GO TO SECTION 2

### SECTION - 2 UNIT DETAILS

Q - 1) Kindly tell us to which industrial segment does your unit belong to. **Single Coding Only**

Industrial Segment	Code	Industrial Segment	Code
Automobile & auto parts	1	Chemicals/ Paint/Powder	9
Casting	2	Electroplating	10
Die Casting	3	Industrial Fasteners	11
Foundry	4	Plastic/ Plastic products	12
Forgings	5	Railway Equipment	13
Heat Treatment	6	Rubber Products	14
Sheet Metal Components	7	Textile & Readymade Garments	15
Fabrication	8		

Q - 2) Kindly tell us the kind of ownership of the unit. **Single Coding Only**

Public Ltd.	1	Central Govt. Undertaking	5
Private Ltd.	2	State Govt. Undertaking	6
Partnership	3	Co-operative	7
Sole Proprietorship	4	Others Please Specify _____	

Q - 3) Kindly tell us the year of establishment of the unit.

Month	Year

Q - 4) Kindly tell us how old your unit is. By this we mean how many years have passed since you started manufacturing in your unit.

Age	Code	Age	Code
0 - 5 years	1	16 - 20 years	4
6 - 10 years	2	More than 20 years	5
11 - 15 years	3		



Q -5) Kindly give us the following details when it comes to employees of this unit. All the numbers should be the most recent ones.

Head	Number
Number of Permanent employees	
Number of Contract based employees	
Number of Male employees	
Number of Female employees	

Q - 6) Kindly tell us the Top 5 products manufactured / value added by you in 2011- 2012. Kindly also tell us the production details of these products in 2011-2012. Interviewer to take details of top 5 products only.

S. No.	Top 5 Products	Annual Production Quantity in pieces (2011 -12)
1		
2		
3		
4		
5		

Q - 7) Kindly tell us what percentage of your annual turnover has come from exports over the last 3 years.

	2009-10	2010-11	2011-12
Annual Turnover(In Lacs)			
% Exports			

Q -8) Kindly tell us if your company is a member of any industrial association?

Yes	1
No	2

Q -9) ASK ONLY IF CODED 1 IN Q -8. Please mention the full name of the association.

---

Q - 10) Please specify the level of this association of which your unit is a member.

Level of Association	Use Code
Local/ District Level Association	1
State Level Association	2
Regional Association (Example: For Northern Region)	3
National Association	4

**SECTION - 3 PLANT MACHINERY & EQUIPMENT DETAILS**

Q -11) Kindly tell us the kind of machines / equipment used in your plant. Multiple Coding Allowed.

Machine/ Equipment	Code	Machine/ Equipment	Code
Furnace	1	Power Press	12
Oven	2	Blower	13
Heater/ Heat tank	3	Air Compressor	14
Boiler	4	Mixer	15
Die casting Machine	5	Electric Motor	16
Pressure die casting Machine	6	Pulverizer or Grinder	17
Pumps	7	Conveyor Belt System	18
Shearing Machine	8	Lathe Machine	19
Rolling Machine	9	Heat Barrel ( Electroplating)	20
Kneader Machine	10	Plastic Extruder Machine	21
Power Loom	11	Chiller / VAM	22
Other ( Pls Specify)		Rubber Molding	23
		Injection Molding	24
		Blow Molding	25
		Other ( Pls Specify)	

Q -12) ASK ONLY IF CODED 1 IN Q-11. Kindly tell us the type of furnaces being used, number of each type of furnace and capacities of furnaces. (Capacity of furnace will be in Tonnes & KW)

Type of Furnace	Code	Nos	Capacity _1	Capacity _2	Capacity _3
Oil Furnace	1				
Gas Furnace	2				
Electric Furnace	3				
Diesel Furnace	4				
Mixed Fuel Furnace	5				
Other (Pls specify)					

Q -13) ASK ONLY IF CODED 2 IN Q-11. Kindly tell us the type of ovens being used, number of each type of oven and their capacities. (Capacity of oven will be in Tonnes & KW)

Type of Oven	Code	Nos	Capacity _1	Capacity _2	Capacity _3
Oil Fired Oven	1				
Gas Fired Oven	2				
Electric Oven	3				
Coke Fired Oven	4				
Other (Pls specify)					

Q -14) ASK ONLY IF CODED 4 IN Q-11. Kindly tell us the type of boilers being used, number of each type of boiler and their capacities. (Capacity of boiler will be in Tonnes & KW)

Type of Boiler	Code	Nos	Capacity _1	Capacity _2	Capacity _3
Oil Fired Boiler	1				
Gas Fired Boiler	2				
Electric Boiler	3				
Coal Fired Boiler	4				
Coke Fired Boiler	5				
Waste Heat Boiler	6				
Other (Pls specify)					

Q -15) ASK ONLY IF CODED 8 IN Q-11. Kindly tell us the type of shearing machines being used, number of each type of shearing machine and their capacities. (Capacity will be in Tonnes)

Type of Shearing Machine	Code	Nos	Capacity _1	Capacity _2	Capacity _3
Billet Shearing Machine	1				
Flying Shear Machine	2				
Cold Shearing Machine	3				
Rotary Shearing Machine (Fix & Swivel)	4				
Alligator Shearing Machine	5				
Twister Pipes	6				
Hot End Shearing Machine	7				
Snap Shearing Machine	8				
Plate/ Scrap Shearing Machine	9				
Pinch Roll	10				
Any Other Specify					

Q - 16) ASK ONLY IF CODED 1 IN Q -11. Kindly tell us which kind of furnace are you using in your unit?

Type of Furnace	Code
Cupola Furnace	1
Induction Furnace	2
Any Other (Specify _____)	

Q -17) ASK ONLY IF THE UNIT IS FORGING UNIT OTHERWISE GO TO NEXT QUESTION. Kindly tell us what kind of forging do you use? Multiple Coding Possible

Type of Forging Process Adopted	Code
Drop Forging	1
Press Forging	2
Offset Forging	3
Automatic Hot Forging	4
Roll Forging	5
Net shape and near net shape forging	6
Induction Forging	7
Cold Forging	8
Any Other (Specify _____)	9





Q -18) ASK ONLY IF CASTING OR DIE CASTING IS CARRIED OUT IN THE UNIT ELSE GO TO NEXT QUESTION.  
Kindly tell us which type of Casting process is used in your unit.

Type of Casting Process Adopted	Code
Die Casting	1
Gravity Casting	2
Sand Casting	3
Pressure Die Casting	4
Any Other (Specify _____)	

#### SECTION - 4 ENERGY CONSUMED

Q - 19) Kindly tell us the amount of fuel used by you in 2011 - 2012 and the money spent.

Type of Fuel	Code	Annual Fuel Consumption Quantity			Annual Bill of Fuel (INR)	
		2010-11	2011-12	Unit	2010-11	2011-12
Coal	1			Tonnes		
Wood	2			Tonnes		
Diesel	3			Litres		
Petrol	4			Litres		
Kerosene	5			Litres		
Furnace Oil	6			Litres		
Lubricant Oil	7			Litres		
Grease	8			kg		
Producer Gas	9			Cubic Metres		
Liquefied Petroleum Gas (LPG)	10			kg		
Compressed Natural Gas (CNG)	11			Cubic Metres		
Electricity	12			kWh( units)		
Any Other (Please specify _____)				_____		



Q -20) Kindly tell us the percentage split of amount of money used on different fuel types.

Type of Fuel	Code	Source of Fuel( Name/Place of Supplier etc)	% Amount of Total Money Spent on Energy in 2011- 12
Coal	1		
Wood	2		
Diesel	3		
Petrol	4		
Kerosene	5		
Furnace Oil	6		
Lubricant Oil	7		
Grease	8		
Producer Gas	9		
Liquefied Petroleum Gas (LPG)	10		
Compressed Natural Gas (CNG)	11		
Electricity	12		
Any Other (Please specify _____ )	13		
<b>TOTAL</b>			<b>100%</b>

Q -21) Kindly tell us are you using Diesel Gen Set for your unit as a back up source of power.

Yes	1
No	2

Q - 22) ASK IF CODED 1 IN Q-21 ELSE GO TO NEXT QUESTION. Kindly tell us for how many hours in a month and in a year do you use Diesel Gen Set for operating the plant.

Hours in a month	
Hours in a year	

Q -23) Kindly tell us what is the amount spent by you in a year for operation of Diesel Gen Set.

\_\_\_\_\_

**SECTION - 5 ENERGY EFFICIENCY**

Q - 24) Kindly tell us are you aware of Energy Efficient machines/ equipment?

Yes	1
No	2

Q - 25) ASK ONLY IF CODED 1 IN Q - 24. Kindly tell us if your company has invested in Energy Efficient equipment in the past 3 years.

Yes	1
No	2

Q -26) ASK ONLY IF CODED 1 IN Q-25 ELSE GO TO Q-28. Kindly tell us what kind of equipment/ machine was bought by your company.

\_\_\_\_\_

\_\_\_\_\_

\_\_\_\_\_

Q -27) Kindly tell us how much money was spent by your company in buying the Energy Efficient equipment/ machine. Please mention the sum in INR.

\_\_\_\_\_

Q -28) IF CODED NO IN Q-25 ASK, Kindly tell us whether you are planning to invest in Energy Efficient equipment/ machine in the next 3-4 years.

Yes	1
No	2

Q - 29) ASK ONLY IF CODED 1 IN Q -28. Kindly tell us how much amount will you will be willing to spend on Energy Efficient equipment/ machine. **Single Coding Only.**

Amount Willing to Spend ( INR)	Code
0 - 5 lakhs	1
6 - 10 lakhs	2
11 - 20 lakhs	3
21 - 50 lakhs	4
51 - 75 lakhs	5
76 lakhs - 1 crore	6
1 crore plus	7

Q -30) ASK ONLY IF CODED 2 IN Q-28. What are the reasons for non-willingness to adopt Energy Efficient equipment?

Reasons for non-willingness to adopt energy efficient equipment	Code
Running profitably and therefore feels no need to improve	1
Lack of capital for investing in adoption of energy efficient practices	2
Energy cost is insignificant as compare to total input cost	3
Any other, please specify _____	



Q - 31) Kindly tell us what kind of Energy Efficient practices have you adopted in your plant for saving energy consumed?

---



---



---



---

Q -32) Kindly tell us if you are using any Variable Frequency Drive.

Yes	1
No	2

Q -33) ASK ONLY IF CODED 1 IN Q-32. Kindly tell us where you use Variable Frequency Drives.

Type of Equipment	Code	Use of Variable Frequency Drive (VFD)	
		Yes	No
Blower	1	1	2
Fan	2	1	2
Compressor	3	1	2
Any Other (Specify).....		1	2

Q - 34) Kindly tell us what kind of challenges are being faced by you and industry in Faridabad in particular. The challenges can be in terms of power supply, labour shortage, outdated technology, capital availability etc.

<u>Challenges Faced with respect to</u>	<u>Response</u>
Technology	
Energy / Power	
Marketing	
Raw Material	

Finished products and their quality	
Available manpower and their skills	
Environment Related	
Socio Economic Conditions	

**SECTION - 6 LOAN PROVIDER**

Q – 35) Kindly tell us have you invested in your plant/ unit in the last 5 years?

Yes	1
No	2

Q – 36) ASK ONLY IF CODED 1 IN Q – 35. Kindly tell us from whom you have taken the money/ loan to invest in the plant / unit.

Money/ Loans taken from	Code
Self	1
Family & Relatives	2
Friends	3
Banks	4
Non banking financial corporation	5
Micro Finance Institutions ( MFIs)	6
SIDBI	7
Others ( Pls Specify)	

Q – 37) Are there any constraints faced by the Unit in availing loans by loan provider in your region?

Yes	1
No	2

Q – 37) ASK ONLY IF CODED YES IN Q- 37. If Yes, please specify the type of constraints faced by your unit in availing loans?

<hr style="border: 0; border-top: 1px solid black; margin-bottom: 5px;"/> <hr style="border: 0; border-top: 1px solid black; margin-bottom: 5px;"/>
---

Q - 38) Kindly tell us what is your frequency of availing capital loans from various loan provider?

Frequency of availing loans	Code
Once in a year	1
Once in 2 years	2
Once in 3 years	3
Once in 4 years	4
Once in 5 years	5
Other ( Pls Specify) _____	

THANK THE RESPONDENT FOR THE TIME GIVEN

Annex 2 Database of Units Covered under Survey

S. No.	Name of Unit	Name of Proprietor	Unit Address	Pin. Code	Tel. No.	Mobile
1	PLATO FAB	KL. BHATIA	PLOT NO - 16, INDUSTRIAL AREA, N.I.T., FARIDABAD	121001		9891819040
2	SUNITA ENGINEERING WORKS	VIKASH SHARMA	PLOT NO - 211A, SANJAY COLONY, SECTOR - 22	121005		8860719576
3	SAXENA ENTERPRISES	SARVESH SAXENA	261A, 30 FEET ROAD, SANJAY COLONY, SECTOR - 22	121022	0129-2443072	9810438792
4	SPS ENGINEERING WORKS	MR. SANDEEP	H.NO - 72, GALI NO - 6A, SANJAY COLONY, SECTOR - 22	121005		9582009237
5	NAVDEEP TOOLS	MR. U.P. DALA	MCF - 113/A, SANJAY COLONY, SECTOR - 22, FARIDABAD	121005	0129-6523325	9811429363
6	K.S. ENTERPRISES	MR. SOHAN NARULA	PLOT - 57, SANJAY COLONY, SECTOR - 22	121005	0129-2231620	9312271184
7	NISHANT INDUSTRIES	MR. DHARMENDRA KR	PLOT - 119A, SANJAY COLONY, SECTOR - 22	121005	0129-4120842	9910657735
8	MAX FORGE		PLOT - 246, SECTOR - 24, FARIDABAD	121005	0129-2231122/25	9873121209
9	SHYAM ISPAT		PLOT - 262-K, SECTOR - 24, FARIDABAD	121005	4040930	9811016355
10	SHIVALIK PAINTS LIMITED		PLOT - 262-A/B, SECTOR - 24, FARIDABAD	121005		9711119361
11	SLEDGE HAMMER OIL TOOLS P. LTD	PRADEEP MOHANTY	PLOT - 262-I, SECTOR - 24	121005	0129-4029782	9811032921
12	TASA MICRO SPECIAL PRUPOSE MACHINES PVT. LTD	D. MALLICK	PLOT - 162C, SECTOR - 24	121005	0129-4061084	9873156939
13	GURU NANAK FOUNDRY	MR. RAJINDER SINGH	17A, INDUSTRIAL AREA, N.I.T. FARIDABAD	121001	0129-4057144	9990504444
14	ASB INDUSTRIES PVT. LTD	S.B. MISHRA	22A, INDUSTRIAL AREA, N.I.T. FARIDABAD	121001	0129-4022209	9911900028
15	K.R. CASTINGS PVT. LTD	MR. K.C. MOHANTY	PLOT - 15-A, INDUSTRIAL AREA	121001	0129-2236764	9899488489
16	SIROCCO PRESSINGS PVT. LTD	MR. P.M.S. MENON	15/7, MATHURA ROAD	121002	0129-4045887	
17	P.K. ENGG. & WELDING WORKS	MR. PANKAJ GERA	15-A, INDUSTRIAL AREA, OLD DHANDA COMPLEX, N.I.T		0129-4023077/78	9818649798
18	AUTO PINS INDIA LTD		16, INDUSTRIAL AREA, N.I.T	121001	0129-4155691	9015888890
19	SUPER FINE MACHINE TOOLS	MR. RAM NIWAS	15-A, INDUSTRIAL AREA, FARIDABAD		0129-4025962	9810476052
20	ANEJA STEELS		22-A, INDUSTRIAL AREA, N.I.T	121001	0129-4001056	9810956279
21	SUPER POLYMER	MR. SUJEET KUMAR	17-C/1, INDUSTRIAL AREA, N.I.T		0129-4296300	9250050061
22	VINOD INDUSTRIES PVT. LTD	MR. SANJEEV AGGARWAL	17-B, N.I.T., OPP. WHIRLPOOL, FARIDABAD	121001	0129-2238154	9810062815
23	A.K. HYDRO	ASHOK TRIPATHI	14/4, MATHURA ROAD, BALI NAGAR	121003		9310354565 / 9268725038
24	CITY TEXTILE INDUSTRIES		18, DLF INDUSTRIAL AREA, PHASE - I	121003	0129-2259067	
25	SHIV TOOL ENGINEERS	MR. CHANDRASEN MISHRA	14/4, BALI NAGAR, MATHURA ROAD NEAR BANK OF INDIA	121003	0129-2252724	9811490791
26	GANPAT TEXTILE MILLS	GANPAT	37D, DLF INDUSTRIAL AREA, PHASE - I	121003	0129-4262600	
27	MAJESTIC SEATS (INDIA)	MR. ASHOK SHARMA	16, DLF INDUSTRIAL ESTATE, PHASE - I	121003	0129-2277711	9910397864
28	COLOUR VATIKA	MR. SAHDEV	18-C, DLF INDUSTRIAL ESTATE, PHASE - I	121003	0129-4083055	9810750055
29	INDIGO TECHNOLOGIES	MR. AMIT ANAND	7, OLD HAVELL'S COMPOUND, 14/3, MATHURA ROAD	121003	0129-2273736	9810229196
30	AMBIKA INDUSTRIES		PLOT - 30, INDUSTRIAL AREA, N.I.T	121001		9278325900
31	SUPER INDUSTRIES	MR. DEVENDER SINGH	30, INDUSTRIAL AREA. (OPP. DELITE BANQUET HALL) N.I.T.	121001	0129-2440125	9811209860
32	CONTINENTAL REFRACTORIES	MR. A.C. MADAN	PLOT NO - 42, SECTOR - 25	121004	0129-2232375	9810841160
33	DEVA ELECTRI PVT. LTD (SAI)		PLOT NO - 35, SECTOR - 35	121004		9873098466

S. No.	Name of Unit	Name of Proprietor	Unit Address	Pin.	Tel. No.	Mobile
	ENGINEER)					
34	SHREE BALAJI REFRACTORIES CO.	MR. ANUP GARG	PLOT NO - 47, SECTOR - 25, BALLABGARH	121004	0129-4062225	9810173552
35	AAR ESS AUTO PVT. LTD		PLOT NO - 25, SECTOR - 25	121004	0129-4062558	9899222905
36	FLITE STEEL PVT. LTD		PLOT NO - 13-14, SECTOR - 25	121004	0129-2233170	9311803904
37	ELEN AUTO INDIA LIMITED	MR. S. S. JAIN	PLOT NO - 24, SECTOR - 25	121004	0129-4262008	9811015858
38	WEBTECH ENGINEERING (P) LTD.		PLOT NO - 20, SECTOR - 25	121005	0129-4061901	9311296443
39	VIDHYUT STEEL INDUSTRIES PVT. LTD	MR. KAMAL B. MAHOTRA	PLOT NO - 36-37, SECTOR - 25	121004	0129-4060009	9811082010
40	K.N. ENGINEERING WORKS	MR. A. NANDI	PLOT NO - 2, NEW DLF INDUSTRIAL AREA, FARIDABAD	121003	0129-2278868	9811023021
41	NILECH ENGG WORKS	MR. DILIP KUMAR DANGI	31C/8, DLF PLASE - 1	121003	0129-2250348	9810239508
42	NAGPAL STEELS	MR. VIRENDER NAGPAL	1B/198, NEELAM BATA ROAD, (OPP. HOTEL DELITE) N.I.T	121001	0129-4023018	9311204797
43	UNIVERSAL METAL	ASHISH NARWAL	30/5, WEARWELL CYCLE CO. COMPLEX INDUSTRIAL AREA, N.I.T.	121001	0129-4022776	
44	K. K. ENTERPRISES	AMIT KATARIA	PLOT NO - 140/A, HSIIDC, SECTOR - 31	121003		9811969798
45	VISHWA KARMA ENGG. WORKS	MR RAJKUMAR PANCHAL	PLOT NO - 86, BAKE BIHARI COLONY, TILPAT, FARIDABAD	121003	0129-3955105	9811969798
46	R. K. ENTERPRISES	PAWAN KUMAR	SHOP NO - 120, SANJAY COLONY, SECTOR - 22, N.I.T	121005		9899783848
47	VERMA SPRINGS	S. C. VERMA	B-39, GALI NO - 61, SANJAY COLONY, SECTOR - 23, N.I.T	121005	0129-2440580	9810879391
48	WELLTECH INDUSTRIES	DINESH SHARMA	A - 334, DABUA COLONY NEAR NEW POLICE CHOWKI, N.I.T	121005		9891757571
49	R.B. ENGINEERING	RAMWIKAL	120, MCF, SANJAY COLONY, SECOTR - 22	121005		9953652422
50	P.S. INDUSTRIES	PAWAN CHANDERBHAN	PLOT NO - 493, LAMBA CHOWK, NEAR LUXAMI HARDWARE, MUJESSAR	121005		9911917638
51	SHARDA ENGINEERING WORKS	RAMANAND CHAUHAN	H.NO - 226, PLOT NO - 83, SANJAY COLONY, SECTOR - 22	121005		9350900543
52	OM ENGINEERING	VIKRAM SINGH	MCF - 97, SANJAY COLONY, SECTOR - 22, N.I.T	121005		9312077568
53	DR. ENGINEERING	N.K. NAYAR	B-68, GALI NO - 61, SANJAY COLONY, SECTOR - 22	121005	0124-2235229	9910959192
54	LUXMI ENTERPRISES	MR. MADAN AGGARWAL	B-47, SANJAY COLONY, BEHIND SECTOR - 23, N.I.T	121005		9811927175
55	BACHMAN INDUSTRIES INDIA LTD	MR. KAILASH CHANDRA	PLOT NO - 10, SECTOR - 6, MATHURA ROAD	121006	0129-2241040	
56	P.G. ENGINEERS	MR. S. K. GUPTA	24-B/8, INDUSTRIAL AREA, N.I.T	121001	0129-4027592	9811379220
57	PRESCO MEC AUTOCOMP PVT. LTD		PLOT NO - 9/D, SECTOR - 6	121006	0129-4061224	
58	UNIQUE CRANE SYSTEMS	SUMIT NAGPAL	24-B/7, INDUSTRIAL AREA, NEAR THERMAL POWER HOUSE, N.I.T	121001	0129-4060032	9810610084
59	UNIQUE PACKAGING SYSTEMS	MR. BHARAT GARG	PLOT NO - 24-B/5, INDUSTRIAL AREA, N.I.T	121001	0129-2441919	9818844311
60	NIKKO AUTO LTD		9-G, SECTOR - 6		0129-2242531	
61	SBJ PRECISION TOOLS	MR. PARAM DEV SINGH	20-A/10, DHANDA COMPLEX, INDUSTRIAL AREA, N.I.T	121001	0129-4024613	9811441555
62	KIRAN PACKAGING INDUSTRIES	MR. AMIT SINGLA	PLOT NO - 10, SECTOR - 24	121005	0129-4061089	9811228654
63	CHERA ENGINEERING WORKS		20/7, INDUSTRIAL AREA OPP. WHIRLPOOL, N.I.T	121001	0129-4024860	7503582465



S. No.	Name of Unit	Name of Proprietor	Unit Address	Pin.	Tel. No.	Mobile
64	DOUBLE ESS K ENTERPRISES	MR. S.S. MINHAS	24-B/10, INDUSTRIAL AREA, N.I.T	121001	0129-4026309	9899440740
65	FINE TURN	GULSHAN NARANG	PLOT NO - 240, SECTOR - 24	121005		9810241122
66	HARYANA GLOBAL LTD.	GOURAV AGARWAL	PLOT NO - 5-B, NORTHERN INDIA CAMPUS, 20/3, MATHURA ROAD	121006	0129-6450563	9810190762
67	BINANI OFFSET PRINTERS & PACKERS	VINOD BINANI	PLOT NO - 6/8A, NORTHERN INDIA COMPLEX, 20/3 MATHURA ROAD	121005	0129-4065025	9810294153
68	SHIV SHAKTI ENGINEERING WORKS	R.S. KAPOOR	PLOT NO - 3/C, NORTHERN INDIA COMPLEX, 20/3, MATHURA ROAD	121005	0129-2210806	9310036334
69	PRAKASH WEBTECH	SAURABH GUPTA	PLOT NO - 2A & 3A, NORTHERN INDIA COMPLEX, 20/3, MATHURA ROAD	121006	0129-2304031	9899571324
70	HI - MECH MFG. CO.		PLOT NO - 245, SECTOR - 24	121006	0129-4064810	9818368728
71	APCO PAINTS & MINERALS	MAHESH GUPTA	PLOT NO - 6/6-A, NORTHERN INDIA COMPLEX	121005	0129-2305015	9891336720
72	RAINBOW PAINTING WORKS	SANJAY SINGHAL	PLOT NO - 6/3, NORTHERN INDIA COMPLEX, 20/3, MATHURA ROAD	121005	0129-4067111	9312708468
73	CENTURY TECHNOLOGY	MR. ASHOK CHOWDHARY	PLOT NO - 6/1, NORTHERN INDIA COMPLEX, 20/3, MATHURA ROAD	121006		9310608289
74	FLOWSTAR ENGINEERING PVT. LTD		PLOT NO - 6 & 7F/2, NORTHERN INDIA COMPLEX, 20/3, MATHURA ROAD	121005	0129-4069661	9310176384
75	VEE GEE ENGINEERING WORKS	MR. G. N. SINGH	PLOT NO - 7F/14, NORTHERN INDIA COMPLEX, 20/3, MATHURA ROAD	121005		9810443350
76	SINAI METALS	MR. AJISH THOMAS	PLOT NO - 6B, NORTHERN INDIA STEEL COMPLEX, 20/3, MATHURA ROAD	121005	0129-2305022	9818535775
77	DIVINE AUTOMATION PVT. LTD		PLOT NO - 20/4, NAPCO GEAR COMPLEX, PLOT NO - 19, MATHURA ROAD	121005	0129-4069664	9899415952
78	AGGARWAL FOUNDRY	AASHISH JINDAL	PLOT NO - 12, SECTOR - 24	121005	0129-2234232	
79	HIND CHEMICALS	NAMAN NARCHAL	PLOT NO - 4 & 5, NEPCO GEAR COMPLEX NEXT TO BHATIA CRANES, SECTOR - 5, NH - 2, 20/4	121005		9810957228
80	NIDHI AUTO LTD.		PLOT NO - 10, SECTOR - 24	121005	0129-3240141	9310057555
81	VULCAN CASTINGS PVT. LTD	VIKRAM CHOPRA	PLOT NO - 356, SECTOR - 24	121005	0129-4027356	9910708800
82	BDS INDUSTRIES	RANJEET SINGH	PLOT NO - 368, SECTOR - 24			9999996893
83	UNIMAX LABORATORIES	VISHANT JAIN	PLOT NO - 07, SECTOR - 24	121005	0129-4021290	
84	HINDUSTAN INDUSTRIES	MANOJ SRIVASTAV	PLOT NO - 3, SECTOR - 24	121005	0129-2234244	9999009821
85	PROCAST INDIA	VIKAS BANSAL	PLOT NO - 8, SECTOR - 24, N.I.T	121001	0129-4010222	9810709380
86	A.P. ENGINEERING WORKS	RAJESH RAI	PLOT NO - 456, SANJAY COLONY, SECTOR - 23	121005		9716046791
87	KRISHNA POLYMERS	PRADEEP GAUTAM	GALI NO - 23, NEAR MADRASHI MANDIR, SECTOR - 23, SANJAY COLONY	121005		9711455464
88	ACCUTECH INDUSTRIES	RADHY SHYAM SHARMA	PLOT NO - 78, SANJAY COLONY, SECTOR - 22			9873455271
89	ANNAPURNA ENGINEERING WORKS	YOGESH RAWAT	PLOT NO - 16-A, MCF - 67, SANJAY COLONY, SECTOR - 22	121005		9899966942
90	KUBER ENTERPRISES	AMAR NATH SHARMA	H.NO - 15, HOUSING BOARD COLONY, SECTOR - 22	121005	0129-2233106	9873969214 / 9811421914
91	DHARMA PACKAGING	OMKAR SHARMA	H.NO - 45, MCF - 39, SANJAY COLONY, SECTOR - 22	121005		9811052043

S. No.	Name of Unit	Name of Proprietor	Unit Address	Pin.	Tel. No.	Mobile
92	JAI MATA MACHINE TOOLS	AMIT KUMAR	PLOT NO - 83-A, SANJAY COLONY, SECTOR - 22, N.I.T.	121005		9210633422
93	WINGS PRINTERS	S.P. ARORA	A - 101, SANJAY COLONY, SECTOR - 22, N.I.T	121005	0129-2230838	9811321838
94	SHIV ENGINEERING WORKS	RAKESH SHARMA	MCF 681, SANJAY COLONY, SECTOR - 23, NEAR MADRASI MANDIR	121005		9350085703
95	J.S. MACHINE TOOLS	J.S. BARIA	PLOT NO - 67-A, (MCF 10,) SANJAY COLONY, SECTOR - 22, N.I.T	121005	0129-2237139	9312220452
96	ANIL RUBBER MILL PVT. LTD.		PLOT NO - 30, INDUSTRIAL AREA, SECTOR - 6		0129-4065637	
97	INDIA FORGE AND DROP STAMPINGS LIMITED		28, SECTOR - 6	121006	0129-2212245	9811128038
98	T.S. KISAN CO. PVT. LTD		PLOT NO - 8, SECTOR - 6, INDUSTRIAL AREA		0129-4272200	8802248709
99	SNG METALS PVT. LTD		PLOT NO - 44, SECTOR - 6	121006	0129-4107107	8826515728
100	VERMA DIE CASTINGS	MR. NARESH VERMA	PLOT NO - 131 - 140, SECTOR - 6	121006	0129-4067290	9811143837
101	NIPHA EXPORTS (P) LTD.		PLOT NO - 29, SECTOR - 6	121006	0129-2311634	9350208278
102	SHIVA AUTOMAT		PLOT NO - 301, SECTOR - 24	121005	0129-4188000	9871109075
103	METAFAB ENGINEERS (INDIA) PVT. LTD		PLOT NO - 299, SECTOR - 24	121005	0129-2239211	
104	DUA INDUSTRIES	SANJAY DUA	PLOT NO - 226, SECTOR - 24	121005	0129-4066700	9811172992
105	MOHTA BRIGHT STEEL PVT. LTD	MR. M. K. MOHTA	PLOT NO - 258, SECTOR - 24	121005	0129-4061357	9810232223
106	SANKIA APPLIANCES PVT. LTD	MR. DEVENDRA SAKLA	PLOT NO - 65, SECTOR - 24	121005		9810771999
107	KBEERA HYDRAULIC ENGINEERS (P) LTD	MR. BALWINDER SINGH	PLOT NO - 284 - 285, SECTOR - 24	121005	0129-4188999	9810003646
108	ELMEC TOOLS & DEVICES PVT. LTD		PLOT NO - 257, SECTOR - 24	121005	0129-2232235	9873353512
109	MICRO POWDER TECH	S.C. JAIN	PLOT NO - 48, SECTOR - 24	121005	0129-2238125	9811116490
110	BSL CASTINGES PRIVATE LIMITED	MR. RANJAN GHAI	PLOT NO - 263, SECTOR - 24	121005	0129-4189800	9811268690
111	SANKIA APPLIANCES PVT. LTD	MR. DIRAJ SANKLA	PLOT NO - 64, SECTOR - 24	121005		9310011099
112	SHANKER FORGE PVT. LTD	MR. VISHAL BANSAL	PLOT NO - 132 & 139, SECTOR - 6	121006	0129-2248523	9810520542
113	PUNEET UDYOG		PLOT NO - 37-E, SECTOR - 6	121006	0129-2243031	
114	NORTHERN INDIA LEATHER CLOTH MFG. CO. (P) LTD.		PLOT NO - 16, SECTOR - 6	121006	0129-2241111	
115	KOBE SUSPENSION CO. PVT. LTD		15, INDUSTRIAL AREA, SECTOR - 6	121006	0129-40107215	9818572858
116	FRIENZ AUTO PVT. LTD		PLOT NO - 05, SECTOR - 24	121005	0129-4183500	9711517361
117	NATASHA ENGINEERS PVT. LTD	MR. C.P. DHINGRA	PLOT NO - 8, SECTOR - 24, N.I.T	121005		9350257988
118	HI TECHNO MACHINES	MR. ATUL BALI	PLOT NO - 27, SECTOR - 6	121006	0129-4067125	9810021916
119	SHARMA ENGINEERING INDUSTRIES	UMESH SHARMA	PLOT NO - 136, SECTOR - 6	121006	0129-4067775	
120	PICL (INDIA) PVT. LTD		PLOT NO - 99, SECTOR - 6	121006	0129-4284400	9810055608
121	SHIV MACHINE TOOLS		PLOT NO - 20, A/6 INDUSTRIAL AREA	121001	0129-4100652	
122	INDIANA ENTERPRISES		20, A/6 DHANDA INDURSTRIL COMPLES, N.I.T	121001	0129-4023375	
123	OSWAL CASTING PVT. LTD		PLOT NO - 49, N.I.T., INDUSTRIAL AREA	121006	0129-4260000	
124	SKYTONE ELECTRICALS (INDIA) LIMITED		PLOT - 42 - 43, INDUSTRIAL AREA, N.I.T.	121001	0129-4099800	

S. No.	Name of Unit	Name of Proprietor	Unit Address	Pin.	Tel. No.	Mobile
125	CONSULT TECHNIQUES (I) PVT. LTD		41, INDUSTRIAL AREA, N.I.T.		0129-4024832	9811946096
126	SHREE JWALA JI POLYMERS	SHYAM SHARMA	PLOT NO - 39, INDUSTRIAL AREA, N.I.T		0129-4024311	9891921628
127	SHIV SHAKTI INDUSTRIES	MR. S.R. NAGAR	PLOT NO - 39, INDUSTRIAL AREA, N.I.T	121001	0129-4020157	9810369040
128	GLORIOUS ELECTRONICS (I) PVT. LTD		PLOT NO - 39-40, SHED NOI - 45-48, INDUSTRIAL AREA, N.I.T.	121005	0129-4025025	9654040479
129	ADVANCE COATING	MR. REEMA KALRA	PLOT NO - 340, SECTOR - 58			9811074406
130	K.S. JAIN ENTERPRISES		PLOT NO - B/1, PHASE - 1, SANJAY MEMORIAL INDUSTRIAL ESTATE, 20/2, MATHURA ROAD	121006	0129-2290185	9310976767
131	JYOTI ENGINEERING WORKS	CHANDERHAS	PLOT NO - 29, S.M.I.E. PHASE - I, NEAR MUJESSAR MORE	121006		9810829351/9999590034
132	A.S. STEEL TUBE		PLOT NO - 47,48, S.M.I.E PHASE - II, 20/2, OPP. YMCA	121006	0129-4008805	9310119401
133	SHREE BALAJI STAMPINGS	AMIT GAUR	PLOT NO - 28, S.M.I.E PHASE - II, OPP. YMCA CHOWK, MATHURA ROAD	121006	0129-6524371	9717006168
134	HI-TECH SYSTEMS	MR. RAJU BHATIA	PLOT NO - 57-58, SMIE PHASE - I, 20/2, MATHURA ROAD	121006	0129-4001794	9810777825
135	KANSAL GEARS	MR. PRAVEEN KANSAL	PLOT NO - 8, GALI NO - 3, SMIE, 20/2, MATHURA ROAD	121006	0129-4104402	9811994856
136	BRIGHT AUTO INDUSTRIES		PLOT NO - 31, SMIE, PHASE - I	121006	0129-5005815	9810501045
137	SUPER BEARING ALUMINIUM ALLOYS	MR. ROHIT GUPTA	PLOT NO - 10, SMIE, PHASE - I, 20/2, MATHURA ROAD	121006		9810021632
138	DEEPSHIKHA STAMPINGS	MR. P.K. ARORA	PLOT NO - 77, SMIE, 20/2, MATHURA ROAD	121006	0129-4017170	9810625170
139	SAPNA INDUSTRIES	MR. SANDEEP GUPTA	PLOT NO - 10, SMIE, PHASE - I, 20/2, MATHURA ROAD	121006		9210589295
140	SWITCH TECHNOLOGIES	MR. S.N. JHA	NEPCO GEAR COMPLEX NEXT TO BHAIA CRANES, SECTOR - 5, N.H - 2, 20/4, MATHURA ROAD	121006		9811173464
141	JMC TAPEX INDUSTRIES	MR. GAGGAN DUA	PLOT NO - 12, SMIE, PHASE - I, 20/2, MATHURA ROAD	121006	0129-4067400	9810261300
142	H.U.F & COMPANY	MR. H.S. RAJPUR	PLOT NO - 18, SANJAY MEMORIAL INDUSTRIAL ESTATE	121006	0129-2288616	9811890189
143	GAYATRI ENGINEERS	MR. M.C. GUPTA	PLOT NO - 11, SIME, PART - I, MATHURA ROAD	121006	0129-2287183	9811570682
144	BHURJI MACHINE TOOLS	SURENDER SINGH BHURJI	PLOT NO - 18, SANJAY MEMORIAL INDUSTRIAL ESTATE, 20/2, MATHURA ROAD	121006		9810193871
145	HARI OM ENGINEERING PVT. LTD	PANKAJ GUPTA	PLOT NO - 4B, SMIE, PHASE - I, 20/2, MATHURA ROAD	121006	0129-4058346	9811638346
146	B.M. MACHINE TOOLS	BALGEET SINGH	PLOT NO - 407, JAWAHAR COLONY, OPP. GURUDWARA, N.I.T	121001	0129-2336101	9717736304
147	GURMUCKH MACHINE TOOLS	P.P. SAINI	PLOT NO - 408, JAWAHAR COLONY, OPP. STREET GURUDWARA, N.I.T	121005	0129-2237435	9891539182
148	SHREE DURGA ENGG. WORKS	KUSUM PANDEY	PLOT NO - 191-A, SANJAY COLONY, SECTOR - 22	121005	0129-6514803	9811148934
149	S.K. ENGG. WORKS	SHAMBHU PRASAD	MCF - 138/, GALI NO - 73, SANJAY COLONY, NEAR VAISHNO MATA DEVI MANDIR, 33 FEET ROAD, SECTOR - 22	121005		9899829780
150	R.M. TOOLS ENTERPRISES	BALWINDER SINGH	PLOT NO - 7-8, (MCF 40) WARD NO - 4, SANJAY COLONY, SECTOR - 22	121005	0129-2231481	9910978534
151	SHRI GURU HARKRISHAN TOOLS	SHRI GURU HARDRISHNA TOOLS	H.NO - 394, JAWAHAR COLONY, VISHKARMA GALI, N.I.T	121005	0129-6465430	9015672430
152	TAMANNA INDUSTRIES	PARSHANT VERMA	379, NEAR GURUDWARA, JAWAHAR COLONY	121005		9540023661 / 9891011009
	SHAKTI INDUSTRIES	DHEERAJ	PLOT NO - 416, JAWAHAR COLONY, OPP. GURUDWARA, N.I.T	121005		9810048212 /

S. No.	Name of Unit	Name of Proprietor	Unit Address	Pin.	Tel. No.	Mobile
						9810048216
154	DEEPAK UDYOG	DEEPAK KUMAR JHA	SHADE NO - 51, SHIV COLONY, NEAR SECTOR - 22	121005	0129-2235302	9911661815
155	MANPREET PACKAGING	KURWANT SINGH	H.NO - 395, JAWAHAR COLONY, VISHKARMA GALI, N.I.T	121005		9582450851
156	BHAGIRATHI RUBBER UDHYOG	VINOD NEGI	14, MILE STONE, DELHI, MATHURA ROAD	121008		9810842356
157	JINDAL POLYTUBES PVT. LTD	MADAN JINDAL	PLOT NO - 1-25, DLF INDUSTRIAL ESTATE, PHASE - 1	121003		9811310685
158	PANORMA EXPORTS PVT. LTD		PLOT NO - 8, DLF INDUSTRIAL AREA, PHASE - 1	121003	0129-2252604	
159	RUBIC HARBOTECH	MR. RAJESH KUMAR MEHTA	PLOT NO - 1/32, FIRST FLOOR, DLF INDUSTRIAL ESTATE, PHASE - 1	121003		8802469689
160	JINDAL PIPE INDUSTRIES	ANITA GUPTA	PLOT NO - 1/23, DLF INDUSTRIAL ESTATE, PHASE - 1	121003		9811115616
161	STARTEC POLYMER INDUSTRIES	MR. J.S.C. CHAUDHARY	PLOT NO - 1-13/4, 5&6, DLF INDUSTRIAL ESTATE	121003	0129-4048636	9953753202
162	K.K.K. TEXTILES LIMITED	POWAN KUMAR	H.O :- I-41, DLF INDUSTRIES AREA, PHASE - 1	121003	0129-4113053	9910823767
163	SHUBHAM ENTERPRISES	MR. SHASHI KANT	PLOT NO - 1-13/2, DLF AREA	121003		9350211557 / 9212663817
164	SUTOSTART (INDIA) PVT. LTD		26, DLF INDUSTRIAL ESTATE, PHASE - 1	121003	0129-4262600	7303414616
165	CHIFFON (INDIA)	RAHUL SHARMA	14TH MILE STONE, MATHURA ROAD	121003	0129-4113447	9891212006
166	AKI GLOBAL		PLOT NO - 51/34, INDUSTRIAL AREA, N.I.T	121001	0129-4021422	9467277081
167	STOKER CONCAST PVT. LTD	S.K. DAS	PLOT NO - 7H, N.I.T. INDUSTRIAL AREA	121001	0129-6562171	9811144671
168	PRINTOP LAST	VIJAY KUMAR	PLOT NO - 51/20, INDUSTRIAL AREA, N.I.T	121001		9811389983
169	DEE EMM GIKEN PVT. LTD		PLOT NO - 58-N, INDUSTRIAL AREA, N.I.T	121001	0129-4011390	9811128385 / 9310011390
170	EMSON ENGINEERING WORKS	J.S. NARJALA	PLOT NO - 51/6, INDUSTRIAL AREA, N.I.T	121001		9611436223
171	KARTIK TOOL TECH.	NEERAJ GUPTA	PLOT NO - 51/33, INDUSTRIAL AREA, N.I.T	121001		9212546009 / 9212232440
172	RADHIKA C.K. TOOLS	KAMLESH	PLOT NO - 51/27, INDUSTRIAL AREA, N.I.T	121001		9891439383
173	YODEE COIL CUTTER		PLOT NO - 58/A, INDUSTRIAL AREA, N.I.T	121001	0129-4028777	9899728995
174	ARORA ENTERPRISES		PLOT NO - 51/2, INDUSTRIAL AREA, N.I.T	121001		9910081597
175	MODERN SPRINGS	R.K. ARORA	PLOT NO - 51/11, INDUSTRIAL AREA, N.I.T	121001	0129-4159427	9811213088
176	R.K. INDUSTRIES	DHARMPAL GOSWAMI	PLOT NO - 348, SECTOR - 58	121005	0129-2309424 / 6514585	9891990223
177	NIRANKARI ELECTROPLATERS	MRS. POONAM KHURANA	PLOT NO - 350, SECTOR - 58	121005	0129-4103350	9873172699
178	ASHOKA ENTERPRISES	MR. S.S. TANWAR	PLOT NO - 331, ELECTRO PLATING ZONE, SECTOR - 58	121005	0129-4061111	9311986000
179	METAL TREATMENT CENTER	MR. PARMINDER SINGH	PLOT NO - 338, SECTOR - 58		0129-4151542	9818806338
180	GLORIOUS CORPORATION	MR. HARVINDER SINGH	339, SECTOR - 58		0129-3255548	
181	SHIVALIC PRINTS LTD.		PLOT NO - 48, SECTOR - 6		0129-4061928	9811091382
182	SHREENATH CASTINGS PVT. LTD	SURENDER KUMAR AGARWAL	PLOT NO - 252, SECTOR - 24	121005	0129-4062413	9871948850
183	PRECISION MOULDS	RISHIPAL GUPTA	GALI NO - 5, PLOT NO - 7, KRISHNA COLONY, SECTOR - 25 NEAR PRAKASH ELECTRICAL	121004	0129-2239028	9811084862
184	KAPOOR CHEMICALS	P. C. KAPOOR	PLOT NO - 20, S.M.I.E., PHASE - 1, 20/2 MATHURA ROAD	121006	0129-2281269	9810842142

S. No.	Name of Unit	Name of Proprietor	Unit Address	Pin.	Tel. No.	Mobile
185	DEEPAK ASSOCIATES	GAJENDER SINGH	PLOT NO - 3/B, KRISHNA COLONY, GALI NO - 5-6, SECTOR - 25	121004	0129-4150046	9811282104
186	AMAN DIE CASTING	FARUK KHAN	PLOT NO - 109, GALI NO - 5, KRISHNA COLONY NEAR RELIANCE MOBILE TOWER, OPP. SECTOR - 5	121004		9999086136 / 9560467035-36
187	SHANDILYA DIE CAST	SAMEER SHARMA	PLOT NO - 22, KRISHNA NAGAR, OPP. PLOT N O - 80, SECTOR - 25	121004	0129-4086575	9871107066
188	VIKAS FORGINGS PVT. LTD		PLOT NO - 173, SECTOR - 24	121005	0129-4062345	9818120172
189	KALKAJI ENGINEERING COMPANY	DALIP VERMA	PLOT NO - 248, SECTOR - 24	121005	0129-4062651	9811180101
190	RPL SHOE COMPANY	AMIT GUPTA	GALI NO - 5, KRISHNA NAGAR, OPP. PLOT NO - 77, SECTOR - 25	121006		9910322110 / 9873090765
191	NIRMAN INDUSTRIES	V.P. GUPTA	PLOT NO - 145, SECTOR - 24	121005	0129-4062055	
192	REVA INDUSTRIES LIMITED		PLOT NO - 164, SECTOR - 24	121005	0129-6450444	9650391342
193	ENTEC INDUSTRIAL FURNACES (P) LTD.		PLOT NO - 186, SECTOR - 24	121005	0129-4061104	9650144040
194	AMBIKA ENTERPRISES	SUBHASH CHAND GARG	PLOT NO - 28, PHASE - I, S.M.I.E, 20/2 (OPP. ORIENT FANS)	121006	0129-4003142	9810005927
195	THERMADYNE PVT. LTD	RASHMI NAGA BUSAN	14/7, SECTOR - 27B, MAIN MATHURA ROAD, FARIDABAD	121003	0129-2275708	9958011987
196	BUDS LABORATORIES	S.K. KHURANA	PLOT NO - 56, SECTOR - 27A	121003	0129-2274819	9811000555
197	ALPINE CREATION PVT. LTD	SANJAY LEKHA	PLOT NO - 67-68, SECTOR - 27, MAIN MATHURA ROAD			9901382154
198	FASHIONAGE CORPRATION PVT. LTD	MR. PARMGEET	14 MILE STONE MAIN MATHURA ROAD	121003	0129-4289201	9711067719
199	SUPERTECH ENGINEERS	CHANDRA BHAL TRIVEDI	PLOT NO - 535 - 536, SANJAY COLONY, NEAR MADRASHI MANDIR, N.I.T	121005		9313218641
200	RAJESH STEERING PVT. LTD	S.K. LAKHEDIA	PLOT NO - 3, SECTOR - 27C, MAIN MATHURA ROAD	121003		9911694622
201	SADAN VIKAS INDIA PVT. LTD		15/2, SECTOR - 27A, MAIN MATHURA ROAD	121003	0129-4196000	9313418153
202	KATEX DYEING AND PRINTING MILLS PVT. LTD	S.C. KANAUIJA	VERMA UDYOG COMPOUND - 15/1, MILESTONE, MATHURA ROAD	121003	0129-4088514	9810131398
203	BHARAT FOAM UDYOG PVT. LTD	AMIT JAIN	15/4, MATHURA ROAD	121003	0129-2277856	
204	COIR FORM PVT. LTD	J.P. AGARWAL	14/6, SECTOR - 27B, MAIN MATHURA ROAD	121003	0129-4090512	
205	MELCO INDIA PVT. LTD		PLOT NO - 4, SECTOR - 27A	121003	0129-2276466	9312071520
206	COLORLINE		151, DLF, INDUSTRIAL AREA, PHASE - 1	121003	0129-2250800	9810110158
207	SIDH MASTERBATCHES PVT. LTD		86, DLF INDUSTRIAL AREA, PHASE - 1	121003	0129-4113008	9810568338
208	EXPLICIT LEATHERS	ATUL AGARWAL	PLOT NO - 14/3, MATHURA ROAD	121003	0129-255000	9990108809
209	PSYCHOTROPICS INDIA LTD		141, DLF INDUSTRIAL AREA, MATHURA ROAD	121003	0129-227559	9891306222
210	RICHA PROCESSING MILL (P) LTD.		1-16, DLF INDUSTRIAL AREA, PHASE 1	121003	0129-2275001	9891550085
211	STARLING CASTING	M. S. KHANA	311C/10, DLF INDUSTRIAL AREA, PHASE - 1	121003		9810391752
212	KARAN PROCESSORS PVT. LTD		PLOT NO - 145, DLF INDUSTRIAL AREA, PHASE - 1	121003	0129-4113611	9810700708
213	JSR PLAST PVT. LTD		PLOT NO - 156, PHASE - 1, DLF INDUSTRIAL AREA	121003	0129-403717	9911243004
214	HEM EMBROIDERY PVT. LTD		116-A, DLF PHASE - 1	121003	0129-2270521	9555463034
215	RAM PRATAP ENGG. WORKS	RAM PRATAP JAYSWAL	PLOT NO - 6, INDUSTRIAL AREA, N.I.T	121001	0129-2235195	9811880109
216	BARUN PACK INDUSTRIES		PLOT NO - 8/1, INDUSTRIAL AREA, N.I.T	121001		9310014666
217	V.R. ENTERPRISES	VARINDER SINGH	19/4, INDUSTRIAL AREA, N.I.T.	121001	0129-4109992	9810236305
218	SAI ELECTROPLATERS	MR. JAGDISH PAHUJA	PLOT NO - 462, SECTOR - 58	121004	0129-4100462	9311895638

S. No.	Name of Unit	Name of Proprietor	Unit Address	Pin.	Tel. No.	Mobile
219	ELECTRO COATS		PLOT NO - 467, SECTOR - 58	121004		9811676833
220	KHURANA ELECTROPLATING WORKS	MR. RAJESH KHURANA	PLOT NO - 455, SECTOR - 58	121004	0129-4010344	9810502344
221	GUPTA PLATERS	MR. JAI PRAKASH GUPTA	PLOT NO - 465, SECTOR - 58	121004	0129-4100856	9560927665
222	DISHA ENTERPRISES		PLOT NO - 458, SECTOR - 58	121004	0129-4101458	9311206999
223	RAHUL TECHNIC		PLOT NO - 459, SECTOR - 58	121004	0129-4100459	9891683979
224	NATRAJ ENTERPRISES		PLOT NO - 441, SECTOR - 58	121004	0129-3292718	9810734435
225	BIKRAM METAL FINISHERS	MR. D.S. NEGI	PLOT NO - 426, SECTOR - 58	121004		9999493557
226	RAWT ELECTROPALATERS		PLOT NO - 425, SECTOR - 58	121004		9810070762
227	SIETZ TECHNOLOGIES INDIA PVT. LTD.		PLOT NO - 38, SECTOR - 6	121006	0129-4188605	
228	TAURUS PRECISION FASTENERS	HARJIT SINGH	PLOT NO - 38, SECTOR - 4	121004		9891100082
229	N.K. AUTO ELECTRICAL INDIA (P) LTD.	PREHLAD SINGH CHOUDHARY	PLOT NO - 21, SECTOR - 4, BALABGARH	121004	0129-4060954	9350862808
230	FBT PRIVATE LIMITED	DR. ASHOK BHATIA	PLOT NO - 43, SECTOR - 4	121004		9560448986
231	ULTRA FERRO MET PVT. LTD	MR. RAJEEV CHOPRA	PLOT NO - 14/7, MATHURA ROAD	121003	0129-5026006	
232	MELO PRECISIONS PVT. LTD	K. CHANDRA	PLOT NO - 4, SECTOR - 27A, MAIN MATHURA, ROAD	121003	0129-2276270	9312500237
233	SURYA BATTERY	SANJAY GANDHI	15/2, SECTOR - 27A, MATHURA ROAD	121003		9837502611
234	RENUKA INC.	RENUKA JAIN GUPTA	KOHINOOR PAINTS COMPOUND, 14/5, MAIN MATHURA ROAD	121003	0129-4045801	9717792776
235	MAHALAKSHMI EMBROIDERY	MALIKM ARORA	15/2, SECTOR - 27/A, MATHURA ROAD	121003	0129-4081877	9811021877
236	BASAL FORGES FABRICATION	MR. PANKAJ	PLOT NO - 42, SECTOR - 4	121004	0129-2243101	9818232739
237	SRI AUROBINDO AUTOMOTIVE COMPONENTS		PLOT NO - 18, SECTOR - 4	121004	0129-2302970	9873890228
238	RACHNA SABUN UDYOG	MANUJ MADAN	PLOT NO - 158, SECTOR - 24	121005	0129-2237932	
239	PRIME INDIA POLYMIX (P) LTD		PLOT NO - 132, SECTOR - 24	121005		9711160774
240	HINDUSTAN SILK MILLS		PLOT NO - 157, SECTOR - 24	121005		9873588819
241	NUTECH THERMOPACK		PLOT NO - 7, ROAD NO - W-5, SARURPUR INDL. ESTATE, SOHNA ROAD, (NEAR BHARAT GAS AGENCY)	121007	0129-2443813	9718137060
242	SHAKTI ENTERPRISES	VISHAL SHARMA	PLOT NO - 4, DHARAM KANTA ROAD, OPP. RAJ CRAIN SERVICE MUJESSAR	121006	0129-2230120	9717044101
243	CHINNAMASTIKA HEAT TREATMENT	MADAN	PLOT NO - 38/A, GALI NO - 2, RAMSARUP INDL. AREA COMPLEX, SECTOR - 24, MUJESSAR	121006		9810071144
244	SWAMI FOUNDRY	BALDEV SINGH	PLOT NO - 107, RAMSAROOP COLONY, MUJESSAR	121001		9873438634
245	CHANDRA RUBBER UDYOG	PARVEEN GUPTA	PLOT NO - 35, RAM SAROOP COLONY, NEAR SHIV GANESH DHARAM KANTA, MUJESAR	121005	0129-2230506	9810748981
246	DEEPAK MOULD INDUSTRIES	R.K. SHARMA	PLOT NO - 115, RAMSWAROOP COLONY, (NEAR SHIV GANESH DHARAM KANTA), MUJESSAR	121005	0129-2233280	9958337771
247	T. SONS ENTERPRISES	KAMAL JAIN	PLOT NO - 35/A, RAM SAROOP COLONY, (NEAR SHIV GANESH DHARAM KANTA), MUJESSAR	121005	0129-4020506	9891464029
248	SHYAM FORGINGS		PLOT NO - 28, SECTOR - 24	121005	0129-4021797	9818015019

S. No.	Name of Unit	Name of Proprietor	Unit Address	Pin.	Tel. No.	Mobile
249	J.S. PLASTICS	JASWINDER SINGH	PLOT NO - 84, RAM SARUP INDUSTRIAL COMPLEX, SECTOR - 24, MUJESSAR	121005		9811351365
250	POLAR AUTO AND ENGINEERING INDUSRTIES PVT. LTD		132, DLF, INDUSTRIAL AREA	121003	0129-2252505, 506	9711670464
251	WINGS AUTOMOBILE PRODUCTS PVT. LTD		135, DLF INDUSTRIAL AREA, PHASE - 1, 13/7 MATHURA ROAD	121003	0129-2250829	9899626164
252	J.S. FOUNDRIES	MR. SURJEET SINGH	PLOT NO - 20-A/7, INDUSTRIAL AREA, N.I.T	121001	0129-2232178	
253	KARAN INDUSTRY	MR. KULDEEP SINGH	PLOT NO - 20A/7, INDUSTRIAL AREA	121001	0129-4174086	9810260868
254	DACC INTERNATIONAL PVT. LTD		56B/1, INDUSTRIAL AREA, N.I.T.	121001	0129-4069636	9873426020
255	UNITED FLEXI PACK		PLOT NO - 6, N.I.T. INDUSTRIAL AREA	121001		9811217563
256	CONSULT TECHNIQUES (I) PVT. LTD		51/18, N.I.T.	121001		9717246464
257	VIJAY METAL FORGINGS PVT. LTD	MR. B.B. BHATIA	56A, INDUSTRIAL AREA	121001	0129-420651	9818140510
258	SWASTIK SHIVPRIYA IMPES	MR. AMIT MAKHARIA	PLOT NO - 5, INDUSTRIL AREA, N.I.T	121001		9350134009
259	KOHINOOR RUBBER INDUSTRIAL	S.S. SIDHU	PLOT NO - 26-B, INDUSTRIAL AREA, N.I.T.	121001	0129-4020087, 82	9873646800
260	CHITRA RUBBER UDYOG	SAURABH KHATRI	PLOT NO - 7B, INDUSTRIAL AREA, N.I.T	121001	0129-418285	9871080909
261	BATRA DIE CASTING IND.		PLOT NO - 12, N.I.T., INDUSTRIAL AREA	121001	0129-4034450	9711731732
262	KRISHNA FOUNDRY	SANJEEV ARORA	PLOT NO - 16, GALI NO - 3/E, SARURPUR INDUSTRIAL AREA, SOHAN ROAD, BALLABGARH	121005		9582403166
263	AKHIL CASTER	ARVIND BHARDWAJ	PLOT NO - GALI NO - 8, SARURPUR INDUSTRIAL AREA	121005		9650156760
264	MACHWELL FOUNDRY	GAURAV	GALI NO - 8A, SARURPUR INDL. AREA, SOHANA ROAD	121005		9350632505
265	TARA SHREE ENGINEERING	VINOD KUMAR SINGH	PLOT NO - 24, GALI NO - 9, SARURPUR INDL. AREA	121005		9818801785
266	VEEKAY CASTING PVT. LTD		PLOT NO - 34 & 35, SARURPUR INDL. AREA	121005		8447221600
267	TECHNO CERAMICS	J. MADAN	PLOT NO - 47, SECTOR - 24	121006	0129-2232938	9811392936
268	SHREE RAM CASTING		PLOT NO - 9, GALI NO - 9, SARURPUR INDUSTRIAL AREA	121005		8802622195
269	SINGLA STEEL INDUSTRIES	B.P. SINGLA	GALI NO - 3/4, SARURPUR INDL. AREA, SOHNA ROAD, BALLABGARH	121001		9810271065
270	STEEL FORGING (INDIA)	SANJAY GOEL	PLOT NO - 26, STREET NO - E-2, BEHIND JINDAL GAS, SAROORPUR INDUSTRIAL AREA, SOHNA ROAD, BALLABGARH	121005	0129-2234886	9811292522
271	INDOFORGE INDUSTRIES	MR. P.D. SHARMA	PLOT NO - 9B, GALI NO - 3 (EAST) NEAR SUNDER CHOWK, SARRORPUR INDUSTRIAL AREA, SOHNA ROAD	121005		9811141483
272	DURGA FORGING	ATUL BANSAL	PLOT NO - 2, GALI NO - 8E, SARURPUR INDL. AREA	121005		9953869091
273	PACE EXIM	YUSUF HAFEEZ	158, DLF INDL. AREA, PHASE - I	121003	0129-2273750	9311126027
274	P. E. PRESS FORGE INDIA PVT. LTD		15, MILESTONE MATHURA RAOD, SEC - 31	121003		9416773674
275	MATATECH INDIA		507, SECTOR - 58			9654555234
276	DUSTECH ENGINEERS	RUPAK GUPTA	PLOT NO - 81A, NEW DLF INDUSTRIAL ESTATE, SECTOR - 32	121003		9990063000
277	NARINDRA POWDER COATING	MR. N.K. GUPTA	PLOT NO - 512, SECTOR - 58			9873171307
278	PEE KAY COATS	MR. PARDEEP KR. CHAWLA	PLOT NO - 504, SECTOR - 58, PLATING ZONE, BALLABGARH	121005	0129-2307702	9810757558
279	AMAN ENTERPRISES	MR. K.G. SINGHAL	PLOT NO - 522, SECTOR - 58	121004	0129-2307517	9350129306
280	PERFECT METAL COATINGS	MR. RAJ SINGH	PLOT NO - 498, SECTOR - 58, BALLABGARH	121005	0129-3295584	9811575284
281	GOYAL ELECTRO PLATERS	MR. NAND KISHOR	PLOT NO - 486, SECTOR - 58, ELECTRO PLATING ZONE	121005		9811340912

S. No.	Name of Unit	Name of Proprietor	Unit Address	Pin.	Tel. No.	Mobile
		GOYAL				
282	VAISHNAV CHAUHAN ELECTRO PLATING	MR. NARENDRA CHAUHAN	PLOT NO - 489, SECTOR - 58	121005		9911762542 / 9811375931
283	MAHADEV TECHNO INDUSTRIES	MR. YOGESH SRIVASTAVA	PLOT NO - 492, SECTOR - 58, INDUSTRIAL AREA	121005	0129-3258444	9811392923
284	KRISHNA ENT.	MR. R. N. SIKKA	PLOT NO - 494, SECTOR - 58	121005	0129-307555	
285	M.C. CAP INDUSTRIES	MR. SURESH GOYAL	PLOT NO - 496 - 497, SECTOR - 58, BALLABGARH	121005	0129-3299586	9810964246
286	SAHIL INDUSTRIES	MR. ANIL KR. RATRA	PLOT NO - 503, SECTOR - 58	121004	0129-6514590	9818283202
287	JYOTI ELECTROCOATERS	MR. KHUSHDIL PAHUJA	PLOT NO - 505, SECTOR - 58	121004	0129-4013505	9810398340
288	AMAR METAL UDYOG		PLOT NO - 526, SECTOR - 58, BALLABGARH	121004	0129-2307553	9899662142
289	SUPER SHINE PLATERS	MR. MANDEEP AHLAWAT	PLOT NO - 525, SECTOR - 58	121004	0129-4163112	9818400012
290	ABBASE HARD CHROME PLATERS	MR. TAHIR KHAN	PLOT NO - 521, SECTOR - 58	121004		9212557168 / 9266351389
291	BHARAT ELECTROPLATING		PLOT NO - 520-B, SECTOR - 58, BALLABGARH	121004		
292	KRISHNA ELECTROPLATERS	MR. RAVI TALWAR	PLOT NO - 517, SECTOR - 58, ELECTROPLATING ZONE		0129-2307550	9810712638
293	V.K. ELECTRO PLATERS	WASEEM AHMED	PLOT NO - 516, SECTOR - 58		0129-4017525	9873905868
294	VISHWA ENGINEERING INDUSTRIES	MR. R.S. BAGHEL	PLOT NO - 510, SECTOR - 58 (ELECTROPLATING ZONE)		0129-4101510	9310428315
295	PUSHKAR ENTERPRISES		PLOT NO - 508, SECTOR - 58, IND. AREA			9818159298
296	MARK LACES	SATBIR SINGH	91, DLF INDUSTRIAL AREA, PHASE - I	121008		9711115797
297	GUNNO KNIT PVT. LTD		90/G, DLF INDUSTRIAL AREA, PHASE - 1	121003	0129-2273003	9899987127
298	SONU ENTERPRISES	B.M. SINGH	PLOT NO - 29, GALI NO - 3 & 6, DIVINDING ROAD, SARURPUR SOHNA ROAD, BALLABGARH	121006		9716157522 / 9310834553
299	A.B. CASTING	ARVIND YADAV	PLOT NO - 2, GALI NO - 2, SAROORPUR SOHNA ROAD, BALLABGARH			9311853341
300	AMRIT UDYOG	MR. SUREND SHARMA	PLOT NO - 68, GALI NO - 3 & 6, DIVINDING ROAD, SAROORPUR SOHNA ROAD, BALLABGARH	121007		9891115444
301	KAUSHIK TECHNOLOGY	LAYAK RAM KAUSHIK	E/2, GALI NO - 2, PLOT NO - 31, SARURPUR INDL. AREA	121005		9560798949
302	VNG AUTO MOTIVE		PLOT NO - 4, SECTOR - 24	121006		9555155549
303	AMAN CASTING INDUSTRIES	B.B. MISHRA	PLOT NO - 67, ROAD NO - 4E NEAR SAWARIA DHARAM KANTA, SARURPUR INDL. AREA	121005		9871080445
304	AKHI CASTING	ARVIND BHARDWAZ	GALI NO - 4E, SARURPUR INDL. AREA	121001		9811019149
305	M.M. MAKWELL		PLOT NO - 48, SARURPUR INDL. AREA	121005		9313489394
306	PERFECT PARADISE CASTING	YOGRAAJ MISHRA	PLOT NO - 16, W - 6 LANE, SAROORPUR INDL. AREA, SOHNA ROAD	121005		9311394807
307	A. ES. ENGINEERING PVT. LTD	ANIL SETHI	PLOT NO - 24, GALI NO - 6, VISHKARMA COLONY, SECTOR - 25	121005		9899320812
308	BHATIYA FORGING	MR MANOJ BHATIYA	PLOT NO - 6, ROAD NO - W5, SARURPUR INDL. ESTATE, SOHNA ROAD	121001		9871429597
309	KIRAN MACHINE TOOLS	MR. BALKISHAN JI	KMT, PLOT NO - 21, GALI NO - 1, RAMSWAROOP COLONY, NEAR GANESH DHARAM KANTA, MUJHESAR	121006		9899629031 / 9289317823



S. No.	Name of Unit	Name of Proprietor	Unit Address	Pin.	Tel. No.	Mobile
310	SURINDRA MALLEABLE PVT. LTD	MR. SURINDRA	PLOT NO - 159, SECTOR - 24	121005	0129-2233622	
311	JAYSHREE AUTO INDUSTRIES	MR. SUSHIL JAIN	PLOT NO - 54, SECTOR - 24	121006	0129-4029714	8800995829
312	SHIV CASTINGS	PREM LATA SIGH	PLOT NO - 66, ROAD NO - 3x6, SAROORPUR, INDUSTRIAL AREA, SOHNA ROAD	121006		8527770881
313	SHREE BHAKTI DIE CASTINGS	MR. RAJESH SHARMA	PLOT NO - 6, GALI NO - 8/3, SARURPUR INDL. AREA	121005		9350694116
314	SANKLA CASTING	BHARAT BHUSHAN	GALI NO - 3/E, SARURPUR INDL. AREA, SOHNA ROAD, BALLABGARH	121005		9811163315
315	L.S. CASTING	LAL SINGH	GALI NO - 3/4, SARURPUR INDL. AREA, SOHNA ROAD, BALLABGARH	121005		9810460706
316	UNITED CASTER INDIA	MR. ARVIND ARYA	PLOT NO - 17, GALI NO - 5-E, SARURPUR, INDL. AREA, SOHNA ROAD	121006	0129-2471214	9873428063
317	RANJIT CASTINGS	MR. RANJIT JAIN	PLOT NO - 77, GALI NO - 6, SAROORPUR INDL. AREA NEAR SOHNA ROAD	121005		9911329321
318	MAMTA PLASTICS	NAROTAM	H. NO - 490, WEST CHANWALA COLONY, BALABGARH	121005		9873539672
319	LIGHT LIFE INDIA PVT. LTD		PLOT NO - 52, SECTOR - 27A, MATHURA ROAD	121003		7503118694
320	SAURABH RUBBER PVT. LTD		RAGHBIR COLONY, SIHI GATE, BALLABGARH	121004		9136075320
321	PRINT ROLLS		BBHOODAT COLONY, GALI NO - 2, SIHI GATE, BALLABGARH	121004	0129-2311341	9811361267
322	ATLAS RUBBER WORKS	CHANDER BHAN	PLOT NO - 101, GALI NO - 1, BUDUTT COLONY, BALLABGARH	121004		9212736890
323	GAURAV RUBBER	UDAYVEER SINGH	PLOT NO - 101, GALI NO - 2, BUDUTT COLONY, BALLABGARH	121004		8285753650
324	SUPER ASIAN INDUSTRIES	ANIL GUPTA	SIHI GATE, BALLABGARH	121004	0129-2301227	9811132251
325	ASIAN RUBBER ROLLS	NARISH GOYAL	RAGHBIR COLONY, SIHI GATE, BALLABGARH	121004		9811580599
326	V. B. ENGINEERING	MAAN SINGH	PLOT NO - 48, SANJAY COLONY, SECTOR - 23, N.I.T.	121003	0129-4056700	
327	MA KELA DEVI FABRIC	HEMRAJ BANSAL	B - 1, BHUDUTT COLONY, BALLABGARH	121001	0129-3256481	9868031878
328	AGARWAL FABRICS	ROHIT BINDAL	GALI NO - 1, BHUDATT COLONY, SIHI GATE, BALLABGARH	121004		9360277048
329	J.S.R. STEERING PVT. LTD	SUMIT ARORA	78, NEW DLF INDUSTRIAL AREA	121003		9810757573
330	MM ENGINEERING WORKS	MURARI GARG	RAGHBIR COLONY, SIHI GATE, BALLABGARH	121004		9810629454
331	L.R.S. INDUSTRIES	MR. SUSHIL SHARMA	PLOT NO - 54, SECTOR - 58		0129-2307966	
332	SETHI ENTERPRISES	MR. DEEPAK SETHI	PLOT NO - 58, SECTOR - 58		0129-4002858	
333	PRIYANKA IMPEX PVT. LTD		PLOT NO - 48, SECTOR - 58			9310943345
334	GOEL PLASTI INDUSTRIES	SUDARSHAN GOEL	GALI NO - 4E, SARURPUR INDL. AREA	121005		9266121660
335	AVENUE AUTO APPLIANCES INDUSTRIES		PLOT NO - 59, SECTOR - 58		0129-4156511	9891409732
336	NEELKANTH THERMOPACK INDUSTRIES	MOHIT BREJA	PLTO NO - 38-38, KRISHNA NAGAR NEAR SAINI HOTEL, SECTOR - 25, BALLABGARH	121004		9810673845
337	BHARDWAJ SUPER TOOLS		PLOT NO - 56, SECTOR - 58			9716387535
338	BOBBY RUBBER		PLOT NO - 92, SECTOR - 58		0129-2309292	
339	SUPER PLASTICS & RUBBER PRODUCTS	MR. AMIT	PLOT NO - 50, SECTOR - 58	0	0129-4105449	
340	SHALIMAR ENGINEERS	MR. SANJAY	PLOT NO - 483, SECTOR - 58			9711878324
341	FRIENDS FORGINGS PVT. LTD	MR. J. L. MALHOTRA	PLOT NO - 47, SECTOR - 58		0129-2309299	9810041746
342	ABHISHEK ENTERPRISES	MR. O. K. SHARMA	PLOT NO - 631, SECTOR - 58			9811074427
343	SHAKTI COMPONENT VENTRURES		PLOT NO - 21, GALI NO - 1, KRISHNA COLONY, OPP. SECTOR -	121004	0129-4150584	9212171031

S. No.	Name of Unit	Name of Proprietor	Unit Address	Pin.	Tel. No.	Mobile
	PVT. LTD		25			
344	K.S. DIE CASTER		PLOT NO - 7, KRISHNA COLONY, SECTOR - 25 NEAR SHRIJI DHARAM KATA	121004	0129-4176735	9811028310
345	N. K. ENTERPRISES	RAMESH GUPTA	PLOT NO - 36, KRISHNA NAGAR NEAR SAINI HOTEL INDUSTRIAL AREA, GALI NO - 1	121004		9810262065
346	VELMOLD PLASTIC PVT. LTD	O.P. KAMKOJ	PLOT NO - ILA NO - 1/2 (4-40 - 20 (8-10) SOHNA ROAD, MAGLA GUJRAM	121006		9310091530
347	JAI DURGE TAPE	ANIL	GALI NO - E/2, PLOT NO - 70, SARURPUR INDL. AREA	121005		9999815583
348	TECHNOPLAST ENTERPRISES	AMIT SHARMA	B - 65, LANE NO. - 56, SANJAY COLONY, SECTOR - 23	121005	0129-3294013	9811960013
349	VIPUL PLASTICS	C.M. KHANNA	PLOT NO - 31, SECTOR - 25	121005	0129-2232963	9810178286
350	AMOD PACKERS	RAKESH MISHRA	PLOT NO - 66, STREET NO - 4, SARURPUR INDL. AREA	121004		9811369183
351	AMAN THERMOPACK	AJAY SHARMA	VILLAGE MANGLA, SOHNA ROAD, BALLABGARH			9811102756
352	BHARAT INDUSTRIES INDIA	B. B. LUTHARA	PLOT NO - 12, GALI NO - 1, KRISHNA COLONY, SECTOR - 25	121004	0129-4102753	9910003759
353	KRISHNA FORGINGS	VINOD DABUR	GALI NO - 3E, PLOT NO - 27, SARURPUR IND. AREA	121006		9310607983
354	ALL FORGE & CAST SOURCE INDIA		PLOT NO - 1A, GALI NO - 1, KRISHNA COLONY, SECTOR - 25	121005	0129-6457108	9811100188
355	METAFORGE PVT. LTD	RAJESH ARORA	PLOT NO - 43, GALI NO - 3E, SARURPUR INDL. AREA	121006		9313568114
356	BEAS CASTINGS	NINJAN SINGH	GALI NO - 4, SARUPUR INDL. AREA	121006		9990899788
357	PRECI THERM		PLOT NO - 603, SECTOR - 58			9711202498
358	SARALA ENTERPRISES		PLOT NO - 580, SECTOR - 58			9811447846
359	VISHWAKARMA AUTOMOTIVE PVT. LTD		PLOT NO - 46, SECTOR - 58, BALLABGARH	121004	0129-2307691	9212483485
360	RADO INDUSTRIES LTD.	MR. P. C. GUPTA	101, SECTOR - 25, BALLABGARH	121004	0129-4061235	9811224280
361	ASHUTOSH POLYMERS	MAHAVIR BHARDWAJ	PLOT NO - 8A, ROAD NO - W-7, SAROORPUR, INDL. AREA NEAR SOHNA ROAD	121005	0129-2470037	9868031798
362	SCIENTIFIC KNITS PROCESSORS PVT. LTD	SACHIN AGGARWAL	PLOT NO - 165, SECTOR - 25	121004	0129-4154064	9971091773
363	SHIV SHAKTI ENTERPRISES	MUKESH KUMAR	SUNDER CHOWK, GALI NO - 3, EAST SARURPUR INDL. AREA	121005	0129-2244274	9891178115
364	SHREE JEE CHEMICALS	MOHAN LAL GARG	PLOT NO - E/2, PLOT NO - 1B, SARURPUR INDL AREA, SOHNA ROAD	121006		9810981009
365	R. B. METAL	PREM SINGH	GALI NO - 4, SARURPUR INDL. AREA, SOHNA ROAD	121004		9311651957
366	M. M. ENTERPRIGES	MANISH	PLOT NO - 23, GALI NO - 2E, SARURPUR INDL. AREA	121005		9311747071
367	FUEL SAVE SYSTEM		PLOT NO - 65, GALI NO - 3 & 6, DIVINDING ROAD, SARURPUR, BALLABGARH	121005		9350313751
368	N.R. CASTING	GANPAT RAI	PLOT NO - 30, GALI NO - 3E, SURURPUR, INDL. AREA	121006		9416016981
369	A.D. DIE CASTING	AKHILESHWAR	VILLAGE MANGLA, GUJLAN POST PALI	121006		8901411081
370	EUCHEM CHEMICALS PVT. LTD		PLOT NO - 142, INDUSTRIAL SECTOR - 56	121004	0129-4011626	9891707153
371	PNV STEEL AND ALLOYS PVT. LTD.		PLOT NO - 136, SECTOR - 58	121004		9350535234
372	MICROTHERM ENGINEERS	MR. B. RAMALINGAM	PLOT NO - 116, SECTOR - 58	121004	0129-4163204	9811302503
373	FUTURE FASHION		PLOT NO - 112, SECTOR - 58	121005	0129-2307500	9212310541
374	V. N. M. POLYMERS PVT. LTD	MR. GAUTAM CHOUDHARY	PLOT NO - 363, SECTOR - 9	121006	0129-2280844 / 2261191	9999108825
375	SAROJ CREATION		PLOT NO - 169, SECTOR - 58	121006		8750491230

S. No.	Name of Unit	Name of Proprietor	Unit Address	Pin.	Tel. No.	Mobile
376	ESS ESS ENGINEERS		PLOT NO - 168, SECTOR - 58	121006	0129-4031204	
377	M. H. TEXTILES		14/7, MATHURA ROAD, SECTOR - 31	121003	0129-4043511	9910140100
378	AQUAMET ZENNER INDIA LTD.		39-B, HSIDC INDUSTRIAL ESTATE, SECTOR - 31	121003	0129-2276077	9910744603
379	ANJU TECHNO SERVICES	R. S. TOMER	7A, HSIDC, INDUSTRIAL AREA, SECTOR - 31	121003		9310306891
380	BABA METAL	BLOLA SINGH	PLOT NO - 9, MANGLA NEAR SAROORPUR, SOHNA ROAD, BALLABGARH	121004		9910196027
381	SHREE KRISHNA FOUNDRY		VILLAGE MANGLA, NEAR SAROORPUR, SOHNA ROAD, BALLABGARH	121004		9971140298
382	SHAH METAL		PLOT NO - 36, GALI NO - 4, SARURPUR, INDL. AREA	121005		9711386360
383	CENTURAY ENGINEER PVT. LTD.	JASMIT / BILLU	PLTO NO - 29/7, MANGLA NEAR SAROORPUR, SOHNA ROAD, BALLABGARH	121004		9953184952
384	LAULS LIMITED		PLOT NO - 4, SARURPUR	121005	0129-4023738	9350186918
385	BABA CASTING	AKHILESH	PLOT NO - 52, 55 & 56, GALI NO - 9, SARURPUR INDL. AREA	121005		9810085891
386	RITIK ENTERPRISES	ANIL KUMAR	GALI NO - 41E, SARURPUR INDL. AREA	121005		9811102958
387	V. K. CASTING	SONU	VILLAGE MANGLA NEAR SAROORPUR, SOHNA ROAD, BALLABGARH	121004		9211157958
388	SUPER SCREWS PVT. LTD		PLOT NO - 30, SECTOR - 24	121005	0129-4029811	9582215051
389	VAIBHAV TECHNOLOGY	MR. J. K. BHATIYA	PLOT NO - 2, 3, KRISHNA COLONY, SECTOR - 25	121004		9711170906
390	C & A HEAT TREETERS	MR. ANKUR	PLOT NO - 1B, GALI NO - E/3, SUNDER CHOWK SARURPUR	121004		9810726054
391	PRESSWEL INDUSTRIES		PLOT NO - 152, SECTOR - 24	121005	0129-2233665	9810259900
392	BHATIYA POWDER CODDING	MR. SANJAY BHATIYA	PLOT NO - 26, SAROORPUR INDL. AREA, NEAR SOHNA ROAD	121005		9560490051
393	MARUTI PAINTS & CHEMICALS		PLOT NO - 140, SECTOR - 25	121004	0129-2234917	9810630917
394	RAJESH ENGINEERINGS WORKS	MR. G.S. DAHIYA	PLOT NO - 8298, JAWAHAR COLONY	121004		9810132856
395	EVEREST STEEL FABRICATORS	MR. B. M. M. HAL	TIGAON ROAD, SECTOR - 3, BALLABGARH	121004	0129-2241054	9891206001
396	TRACPARTS	SURENDRA BHALLA	3E/10, B. P. N.I.T., FARIDABAD	121001	0129-2417238	9811449475
397	KIRTIKA ENTERPRISES	MR. DINESH GOYALK	GALI NO - 1, BHUDATT COLONY, SIHI GATE, BALLABGARH	121004		9811686858
398	JIVA DESIGNS PVT. LTD		L - 41A, DLF, PHASE - 1	121003	0129-4193000	9958150228
399	ARCOTECH BIOTECH LTD.		PLOT NO - 136, DLF INDUSTRIAL AREA	121003	0129-4009100	
400	SARK EXPORT		I - 10, DLF INDUSTRIAL AREA, PHASE - 1	121003	0129-4127001	